



CT51-71 BT Quick Guide



This guide is intended for quick consultation only and does not replace the user and maintenance manual. Before using the machine, read the user and maintenance manual contained in the machine's packaging thoroughly and strictly follow all the instructions.

PREPARATION & OPERATION

H₂O + CHEM

ON

AUTO

ECO



PUSH

PUSH

PUSH

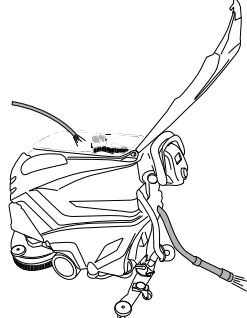
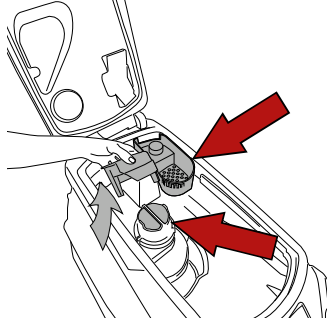
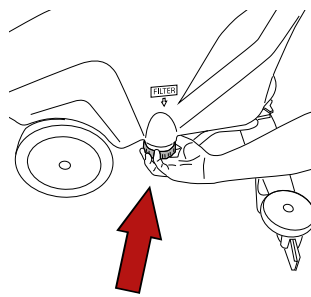
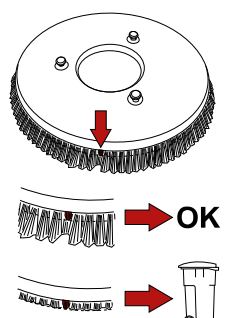
DAILY MAINTENANCE

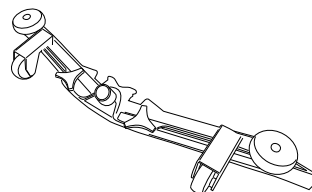
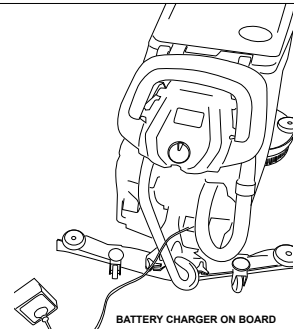
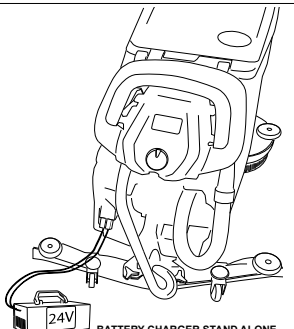
			
<p>Clean the dirty water tank.</p>	<p>Check that the suction filter and dirt filter are clean.</p>	<p>Check that the detergent outlet filter is clean.</p>	<p>Check that the brushes are clean. Replace if necessary.</p>

	 <p>BATTERY CHARGER ON BOARD</p>	 <p>24V BATTERY CHARGER STAND ALONE</p>
<p>Check that the squeegee is clean and the blades are not worn.</p>		

REPLACING THE SQUEEGEE BLADES

Open the clip (Ref. 1).
 Remove the two blade retainers (Ref. 2) by pushing them outwards then extracting them.
 Remove the blade.
 Reuse the same blade by reversing the edge in contact with the floor until all four edges are worn out, or replace with a new blade, fitting it onto the screws on the body of the squeegee.
 Reposition the two blade pressing devices by centering the wider part of the slots on the squeegee body fastening pins, then push the blade pressing devices inwards.
 Close the hook again.
 Replace the squeegee on its support, following the instructions described previously.

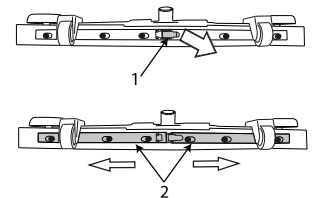

ATTACHING/REMOVING THE BRUSHES

Automatic brush attachment, version with head lift pedal:
 raise the machine head by pushing the head lift pedal (Fig. 1) down and to the left, then using the operation selector, select the Brush control, rest the brush on the floor in front of the machine and centre it with the head. Lower the head by pushing the head lift pedal (Fig. 2) down and to the right and activate the drive lever momentarily; the brush will be attached automatically to the hub on the flange. If the operation is not successful, repeat by pressing the lever again and repeating the centring procedure. Use of abrasive/microfibre disks: fit the abrasive/microfibre disk on the drive disk and perform the operations described for fitting the brush on the scrubber drier.

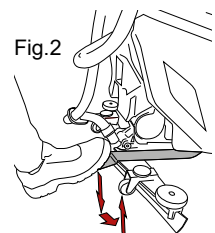
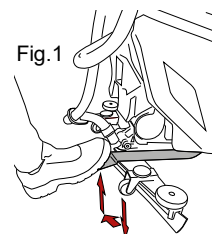

Automatic brush release, version with head lift pedal: raise the machine head by pushing the head lift pedal (Fig. 1) down and to the left, turn the selector to the "OFF" position, press the "SET" button once then press the "-" button, the machine will complete the release sequence.