

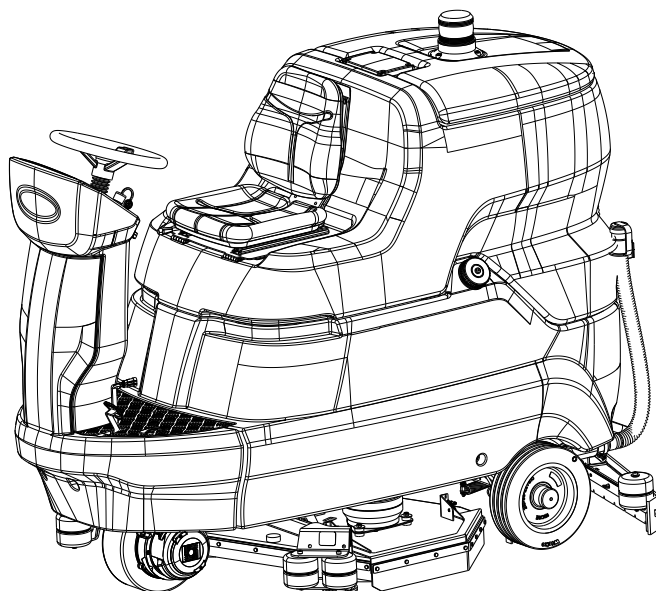

**IPC**

BY TENNANT COMPANY

# CT231

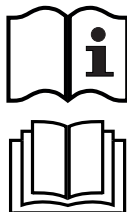

**(IT)** MANUALE ISTRUZIONI PER L'USO  
**(EN)** OPERATOR'S MANUAL  
**(FR)** MANUEL D'INSTRUCTIONS  
**(DE)** BEDIENUNGSANLEITUNG  
**(ES)** MANUAL DE INSTRUCCIONES  
**(NO)** BRUKERHÅNDBOK  
**(NL)** GEBRUIKERSHANDLEIDING  
**(PT)** MANUAL DE UTILIZAÇÃO  
**(SE)** INSTRUKTIONSBOK  
**(RU)** РУКОВОДСТВО ОПЕРАТОРА  
**(BG)** РЪКОВОДСТВО ЗА ЕКСПЛОАТАЦИЯ  
**(DK)** BETJENINGSMANUAL

Consultare attentamente questo manuale prima di procedere a qualsiasi intervento sulla macchina

Read this manual carefully before carrying out any work on the machine

Lire attentivement ce manuel avant toute intervention sur la machine

Vorliegendes Handbuch vor jedem Eingriff an der Maschine aufmerksam durchlesen

Consulte detenidamente este manual antes de llevar a cabo cualquier trabajo en la máquina

Konsulter denne håndbogen nøye før du går i gang med noen som helst type inngrep på maskinen

Raadpleeg deze handleiding aandachtig alvorens met enige werkzaamheid aan de machine te beginnen

Consulte atentamente este manual antes de efectuar qualquer intervenção na máquina

Läs noggrant igenom denna handbok innan du utför något som helst ingrepp på maskinen

Прочетете внимателно това ръководство, преди да започнете работа с машината

Внимательно ознакомьтесь с данной инструкцией до проведения любой работы с машиной

Læs denne brugsanvisning omhyggeligt, inden du udfører arbejde på maskinen

# TABLE OF CONTENTS

|  |           |
|--|-----------|
| <b>IMPORTANT SAFETY PRECAUTIONS</b> .....                                | <b>3</b>  |
| <b>SAFETY SYMBOLS</b> .....  | <b>6</b>  |
| <b>TECHNICAL SPECIFICATIONS</b> .....                                    | <b>7</b>  |
| <b>MACHINE DIMENSIONS</b> .....  | <b>9</b>  |
| <b>GENERAL INFORMATION</b> .....   | <b>10</b> |
| Purpose of this manual .....   | 10        |
| Identifying the machine .....  | 10        |
| Documentation provided with the machine .....                            | 10        |
| <b>TECHNICAL INFORMATION</b> .....                                       | <b>11</b> |
| General description .....  | 11        |
| Main parts of the machine .....  | 11        |
| Control panel.....   | 12        |
| Accessories.....   | 12        |
| <b>HANDLING AND INSTALLATION</b> .....                                   | <b>13</b> |
| Lifting and transporting the palletized machine.....                     | 13        |
| Inspection on delivery .....   | 13        |
| Unpacking .....  | 13        |
| Batteries.....   | 14        |
| Machine Battery Selection Setting .....                                  | 14        |
| WET batteries, preparation: .....  | 15        |
| Batteries: installation and connection.....                              | 15        |
| Choosing the battery charger.....  | 16        |
| Preparing the battery charger .....                                      | 17        |
| Battery charger settings .....   | 17        |
| Fitting the squeegee.....  | 17        |
| Squeegee adjustment .....  | 17        |
| Installation of Brush / Drive disc .....                                 | 18        |
| Installation of brushes (roller head model).....                         | 19        |
| Installation of side brushes (roller head model).....                    | 20        |
| Filling the detergent tank.....  | 20        |
| Chem Dose – (Chem Dose model).....                                       | 21        |
| Select the percentage dilution of the detergent – (Chem Dose model)..... | 21        |
| <b>PRACTICAL GUIDE FOR THE OPERATOR</b> .....                            | <b>23</b> |
| Clothing and equipment .....   | 23        |
| Before starting the machine .....  | 23        |
| Preparing the machine for work .....                                     | 23        |
| Working .....  | 23        |
| Service brake and parking brake .....                                    | 25        |
| “Double Scrubbing” Method .....  | 26        |
| Picking up water (without washing).....                                  | 27        |
| During operation of the machine.....                                     | 27        |
| Emergency stop button .....  | 27        |
| Detergent solution tank empty indicator.....                             | 28        |
| Dirty water tank full indicator.....                                     | 28        |
| Battery charge indicator .....   | 28        |
| Emptying the dirty water tank.....                                       | 28        |
| Emptying the solution tank.....  | 29        |
| Emptying the debris bin (roller head model).....                         | 29        |
| Removing the the brush/pad drivers .....                                 | 29        |
| Moving the machine when not in operation.....                            | 30        |
| <b>MAINTENANCE INSTRUCTIONS</b> .....                                    | <b>31</b> |
| Maintenance - General rules.....   | 31        |
| Cleaning the vacuum motor air filter .....                               | 31        |
| Cleaning the dirty water tank sensor.....                                | 31        |
| Cleaning the debris container .....                                      | 32        |
| Cleaning the solution tank filter .....                                  | 32        |
| Cleaning the Chem Dose tank filter (Chem Dose model).....                | 32        |
| Fuses: .....   | 33        |
| Checking the electrolyte level of WET batteries.....                     | 34        |
| Automatic top-up system for 320Ah WET battery.....                       | 34        |
| Recharging the batteries.....  | 35        |
| Battery: removal .....   | 36        |
| Replacement of Brushes and Pads.....                                     | 36        |
| Replacing the squeegee blades.....                                       | 36        |
| Side brushes wear adjustment(roller head model).....                     | 37        |
| Machine Jacking .....  | 37        |
| Periodic checks .....  | 38        |
| <b>PERIODS OF INACTIVITY</b> .....                                       | <b>38</b> |
| <b>TROUBLESHOOTING</b> .....   | <b>39</b> |
| <b>ALARMS/WARNINGS DISPLAYED</b> .....                                   | <b>41</b> |
| <b>DRIVE WHEEL PCB ALARMS</b> .....                                      | <b>42</b> |
| <b>USER MENU</b> .....   | <b>43</b> |

## **IMPORTANT SAFETY PRECAUTIONS**

Parts of the text requiring special attention are printed in bold and preceded by the symbols illustrated and described below.



### **! DANGER:**

Indicates the need for care in order to avoid serious consequences that could lead to the death of personnel, or to situations representing a possible health and safety hazard.

### **! ATTENTION:**

Indicates the need for care in order to avoid serious consequences that could involve harm being done to the machine or to the workplace, or lead to economic losses.



**! DANGER:** If lead-acid (WET) batteries are installed in the machine, keep sparks, flames and smoking materials away from the batteries. Explosive gases can escape during normal use, particularly when recharging the batteries.



**! DANGER:** If lead-acid (WET) batteries are installed in the machine, charging the batteries produces highly explosive hydrogen gas. Keep the operator seat tilted toward the steering wheel throughout the battery charging cycle and carry out this procedure only in well-ventilated areas, away from naked flames.



**! DANGER:** Never use the machine to clean up flammable or explosive liquids (e.g. petrol, fuel oil, etc.), acids or solvents (e.g. paint thinners, acetone etc.) even if diluted.



**! DANGER:** Never pick up burning or incandescent objects.



**! DANGER:** This machine must not be used on floors where there are hazardous coatings / finishes / materials.



**! DANGER:** Do not spray flammable liquids.

### **Do not use the machine:**

- without having read the operating and maintenance manual.
- without having been trained in its use.
- without having been specifically entrusted with its use.
- if legally under age.
- if the machine is not working properly.
- in places without adequate lighting.
- in explosive environments.
- on public roads.
- outdoors: the machine must be used only indoors.
- where there is dirt that can be harmful to health (dust, gas, etc.).
- where there is danger of falling objects.
- In areas that are too dark to see the controls or operate the machine in safety.

### **Clothing and equipment:**

- Wear safety shoes with non-slip soles.
- Wear protective eyewear or visor and safety garments.
- Depending on the surface being cleaned and on the environment, the protective measures necessary for atomized sprays include respiratory masks with class FFP2 or equivalent or higher protection.

### **Before starting the machine:**

- Check that the machine is not damaged.
- Check the operation of the brake.
- Check that all safety devices are in place and operating correctly.

### **When using the machine:**

- The machine must be operated by one person only.
- Be careful to follow the safety regulations of the particular workplace regarding wet floors. When necessary, place safety signs on the wet floor while using the machine
- Park the machine on a flat, level surface.
- Do not allow children to play on or near the machine.
- Evaluate the type of building the machine is operating in (e.g: hospitals, pharmaceutical or chemical industries, etc.) and scrupulously comply with the safety regulations and conditions in force in these facilities.
- The machine must not be used for purposes other than those expressly intended.
- The machine is intended for commercial use, for example in hotels, schools, hospitals, factories, shops, offices and business premises generally. Do not use for other purposes.
- Keep all parts of body within the riding position while the machine is in motion.
- The machine can be used only indoors.
- The machine must be stored only indoors.
- Do not allow the machine to be used as a toy.
- The machine is not designed for towing or being towed.
- Never rest objects of any significant weight on the machine, for whatever reason.
- Never obstruct the air inlet and release vents.
- Never remove, modify or by-pass safety devices.
- The machine has been designed for use with detergents

supplied or recommended by the manufacturer. The use of other detergents or chemicals can affect the safety of the machine.

- When using floor cleaning products, follow the instructions and warnings on the labels of the bottles.
- Do not use detergents that may produce dangerous reactions, vapours, heat, etc.
- During use, atomized spray may form. Inhaling this atomized spray can be harmful to health.
- Work providers must conduct a risk assessment in order to specify the necessary protective measures relating to the formation of atomized sprays, depending on the surface being cleaned and the environment. Masks with class FFP2 or equivalent or higher protection are suitable for protecting against the inhalation of atomized spray.
- Keep hands away from moving parts.
- In the case of malfunction and/or faulty operation, turn the machine off immediately (disconnect from the batteries/ mains power supply) and do not tamper with it; contact a service centre approved by the manufacturer.
- The machine is designed to operate in temperatures between +4 °C / 39.2 °F and +40 °C / 104 °F, and when not in use, can be stored in temperatures between +0° C / 32° F and +50 °C / 122 °F.
- The machine is designed to operate at relative humidity levels between 30% and 95%.
- The machine must operate at an altitude of less than 2000 m / 6561.68 ft.
- Do not use the machine to clean surfaces on slopes or gradients steeper than indicated on the data plate.
- Do not operate the machine on slopes or gradients steeper than indicated on the data plate.
- When using the machine on gentle gradients, do not move transversely across the slope, but keep the machine on a line parallel to the direction of the incline, manoeuvring carefully and without making U-turns.
- The machine must not be used by persons (including children) with diminished physical, sensory or mental capabilities, or lack of experience and knowledge, unless they are supervised by a person responsible for their safety and have received instruction in the use of the machine.
- Never use the machine to transport people or goods or for towing.
- Do not wear jewellery, watches, ties or other items.
- The operator must always use Personal Protective Equipment: protective apron or overalls, non-slip waterproof shoes, rubber gloves, protective eyewear and ear defenders, and mask for protection of the respiratory airways.

#### **Before leaving the machine or before maintenance:**

- Park the machine on a flat, level surface.
- Turn off the machine and remove the ignition key.
- Apply the parking brake.

#### **When performing maintenance:**

- All operations must be carried out in conditions guaranteeing adequate visibility and lighting.
- Isolate the machine from its power source by disconnecting the batteries.







- The operator must always use Personal Protective Equipment: protective apron or overalls, non-slip waterproof shoes, rubber gloves, protective eyewear and ear defenders, and mask for protection of the respiratory airways.
- Do not wear jewellery, watches, ties or other items.
- Do not push or tow the machine without an operator sitting in the driving seat and able to control the steering wheel.
- Protect the batteries from impurities such as metal dust.
- Take care when handling battery acid, and avoid contact. In the event of battery fluid leakage, do not touch the fluid and observe the following precautions: Contact with the skin can cause irritation; wash with soap and water. Inhalation of vapours can cause irritation to the airways; stay out in the open air and consult a doctor. Contact with the eyes can cause irritation; wash the eyes immediately, flooding with water for at least 15 minutes, and consult a doctor.
- Never rest tools on the batteries as they could cause short circuits leading to explosions.
- Always use the battery charger accompanying the machine (if supplied), or if not, a product with specifications as recommended in the technical data.
- Installation of the battery should be entrusted to a IP CLEANING approved service technician.
- Inspect the power cable of the battery charger periodically to ensure that it is not damaged; in the event of damage being discovered, the appliance cannot be used. Replacement of the cable should be entrusted to a IP CLEANING approved service technician. Detach both connections of the battery charger (AC side and DC side).
- Do not tug at the battery charger cable to disconnect it from the socket: grip the plug firmly and pull.
- Never wash the machine with water jets.
- Cleaning and maintenance operations that can be performed by the user must not be entrusted to children unless under supervision.
- All repairs must be carried out by a IP CLEANING approved service technician.
- Use only original accessories and spare parts supplied exclusively by the manufacturer, as only these are able to guarantee safe and trouble-free operation of the machine.
- Never use parts removed from other machines or from other kits.

**When the machine is to be loaded onto or unloaded from a vehicle:**

- Empty the tanks before loading the machine.
- Raise the scrub head and remove the squeegee from the machine.
- Do not drive the machine on a slippery ramp.
- Take particular care when operating the machine on ramps.
- Turn off the machine and remove the ignition key.
- Apply the parking brake.
- Lock the wheels of the machine.
- Use straps to anchor the machine.

**KEEP THESE INSTRUCTIONS SAFE.**

## SAFETY SYMBOLS

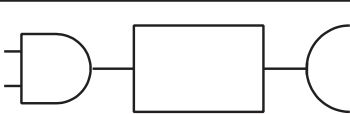
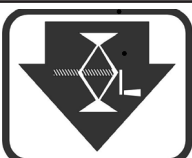
|   |  |
|---|--|
|    | <p>WARNING! RISK OF CUTTING</p>  |
|    | <p>WARNING! RISK OF ABRASION</p>   |
|    | <p>MAXIMUM SLOPE</p>   |
|    | <p>OPERATOR MANUAL, INSTRUCTIONS FOR USE</p>   |
|    | <p>READ THE OPERATOR MANUAL</p>  |
|    | <p>DIRECT CURRENT SYMBOL</p>   |
|  | <p>INSULATION CLASS: THIS CLASSIFICATION ONLY APPLIES TO BATTERY POWERED MACHINES.</p> |
|  | <p>EXTERNAL BATTERY CHARGER CONNECTION POINT.</p>                                      |
|  | <p>LIFTING POINTS ON THE MACHINE.</p>  |

# TECHNICAL SPECIFICATIONS

|                                      |  |                    | Disk 90cm             | Disk 105cm            | Rollers 100cm         |
|--------------------------------------|--|--------------------|-----------------------|-----------------------|-----------------------|
| Cleaning width                       |  | mm                 | 897                   | 1049                  | 984                   |
|                                      |  | inch               | 35.31                 | 41.30                 | 38.74                 |
| Squeegee width                       |  | mm                 | 1180                  | 1380                  | 1380                  |
|                                      |  | inch               | 46.45                 | 54.33                 | 54.33                 |
| Cleaning capacity per hour           |  | m <sup>2</sup> /h  | 6458                  | 7553                  | 7085                  |
|                                      |  | ft <sup>2</sup> /h | 69518                 | 81298                 | 76260                 |
| Number of brushes                    |  | n°                 | 2                     | 2                     | 2                     |
| Brush diameter                       |  | mm                 | 460                   | 530                   | 180x984               |
|                                      |  | inch               | 18.11                 | 20.86                 | 7.08x38.74            |
| Maximum brush pressure               |  | Kg                 | 85                    | 116                   | 37                    |
|                                      |  | lbs                | 187.39                | 255.74                | 81.571                |
| Brush rotation speed                 |  | g/1°               | 200                   | 200                   | 1000                  |
| Brush motor power                    |  | W                  | 400x2                 | 500x2                 | 1000                  |
|                                      |  | HP                 | 0.53x2                | 0.67x2                | 1.34                  |
| Side Brush rotation speed            |  | g/1°               | /                     | /                     | 95                    |
| Side Brush motor power               |  | W                  | /                     | /                     | 60x2                  |
|                                      |  | HP                 | /                     | /                     | 0.08x2                |
| Drive motor power                    |  | W                  | 560                   | 560                   | 560                   |
|                                      |  | HP                 | 0.75                  | 0.75                  | 0.75                  |
| Vacuum motor power                   |  | W                  | 650                   | 650                   | 650                   |
|                                      |  | HP                 | 0.87                  | 0.87                  | 0.87                  |
| Machine power (P <sub>M</sub> )      |  | W                  | 2880                  | 3060                  | 3060                  |
|                                      |  | HP                 | 3.86                  | 4.1                   | 4.1                   |
| Maximum speed                        |  | Km/h               | 7.2                   | 7,2                   | 7,2                   |
|                                      |  | mph                | 4.47                  | 4.47                  | 4.47                  |
| Solution tank                        |  | L                  | 218                   | 218                   | 218                   |
|                                      |  | gal                | 57.58                 | 57.58                 | 57.58                 |
| Dirty water tank                     |  | L                  | 237                   | 237                   | 237                   |
|                                      |  | gal                | 62.60                 | 62.60                 | 62.60                 |
| Front wheel diameter                 |  | mm                 | 300                   | 300                   | 300                   |
|                                      |  | inch               | 11.81                 | 11.81                 | 11.81                 |
| Rear wheel diameter                  |  | mm                 | 305                   | 305                   | 305                   |
|                                      |  | inch               | 12.0                  | 12.0                  | 12.0                  |
| Negotiable gradient                  |  | %                  | 16                    | 16                    | 16                    |
| Gross weight (GVW) (**)              |  | Kg                 | 1134                  | 1150                  | 1175                  |
|                                      |  | lbs                | 2500.04               | 2535.32               | 2590.43               |
| Transported weight without batteries |  | Kg                 | 434                   | 450                   | 475                   |
|                                      |  | lbs                | 956.81                | 992.08                | 1047.2                |
| Transported weight                   |  | Kg                 | 824                   | 840                   | 865                   |
|                                      |  | lbs                | 1816.61               | 1851.88               | 1907                  |
| Machine voltage V <sub>M</sub>       |  | V                  | 36                    | 36                    | 36                    |
| Number of batteries                  | GEL                                      | n°                 | 6                     | 6                     | 6                     |
| Individual battery capacity          |  | Ah (5h)            | 240                   | 240                   | 240                   |
| Individual battery weight            |  | Kg                 | 46                    | 46                    | 46                    |
|                                      |  | lbs                | 101.41                | 101.41                | 101.41                |
| Number of batteries                  | WET-ACID                                 | n°                 | 1                     | 1                     | 1                     |
| Individual battery capacity          |  | Ah (5h)            | 320                   | 320                   | 320                   |
| Battery weight                       |  | Kg                 | 390                   | 390                   | 390                   |
|                                      |  | lbs                | 859.8                 | 859.8                 | 859.8                 |
| Supply voltage (battery recharge)    | Version without on board battery charger | V                  | 36 dc                 | 36 dc                 | 36 dc                 |
| Max current (battery recharge)       |  | A                  | 40                    | 40                    | 40                    |
| Mains supply voltage                 | Versions with on board battery charger   | V                  | 100-240 ac<br>50-60Hz | 100-240 ac<br>50-60Hz | 100-240 ac<br>50-60Hz |
| Max current (amperes) I              |  | A                  | 7                     | 7                     | 7                     |

|  |                           |                |                |                |
|--|---------------------------|----------------|----------------|----------------|
| Machine dimensions   | mm                        | 2006           | 2006           | 2016           |
|  | X<br>Z<br>Y               | 1180<br>1508   | 1376<br>1508   | 1376<br>1508   |
|  | inch                      | 78.98          | 78.98          | 79.37          |
|  | X<br>Z<br>Y               | 46.46<br>59.37 | 54.17<br>59.37 | 54.17<br>59.37 |
| Battery compartment dimensions (length, width, height)                       | mm                        | 620            | 620            | 620            |
|  |                           | 440<br>530     | 440<br>530     | 440<br>530     |
|  | inch                      | 24.41          | 24.41          | 24.41          |
|  |                           | 17.32<br>20.87 | 17.32<br>20.87 | 17.32<br>20.87 |
| Machine dimensions without squeegee (length, width, height)                  | mm                        | 2006           | 2006           | 2006           |
|  |                           | 982<br>1508    | 1160<br>1508   | 1171<br>1508   |
|  | inch                      | 78.98          | 78.98          | 78.98          |
|  |                           | 38.66<br>59.37 | 45.67<br>59.37 | 46.10<br>59.37 |
| Sound pressure - Annex DD (Emission of acoustical noise) EN 60335-2-72: 2012 | LpA<br>(dBA)              | 76             | 76             | 79             |
| Measurement uncertainty  | K<br>(dBA)                | 3              | 3              | 3              |
| Vibration level (hand) - IEC 60335-2-72                                      | ahv<br>m/sec <sup>2</sup> | ≤2,5           | ≤2,5           | ≤2,5           |
| Vibration level (body) - IEC 60335-2-72                                      | HBV<br>m/sec <sup>2</sup> | ≤0,5           | ≤0,5           | ≤0,5           |
| Maximum water and detergent temperature                                      | °C                        | 55             | 55             | 55             |
| IP degree  | IP                        | IPX3           | IPX3           | IPX3           |
| Aisle turnaround width (with or without side brushes)                        | mm                        | 2310           | 2440           | 2570           |
|  | inch                      | 90.94          | 96.06          | 101.18         |

(\*\*) Gross weight (GVW): maximum permissible weight of the machine ready for use and with full tanks. The gross weight of the machine includes the detergent solution tank full of clean water, empty dirty water tank, empty dust bags, the hopper filled to its rated capacity, the largest recommended batteries and all accessories such as cables, hoses, detergent, mops and brushes.

Transported weight: the weight of the machine including batteries, but excluding optionals (for example, operator's cabin, FOPS — Falling Object Protective Structure — second and third side brushes and front brush attachment), fresh water (in the case of scrubbers or combination machines) and the weight of a standard operator (75 Kg - 165.35 lbs).

Data subject to changes without prior warning

V, I: charging / supply values

V<sub>M</sub>, P<sub>M</sub>: machine in average operating conditions (all functions active)



# MACHINE DIMENSIONS

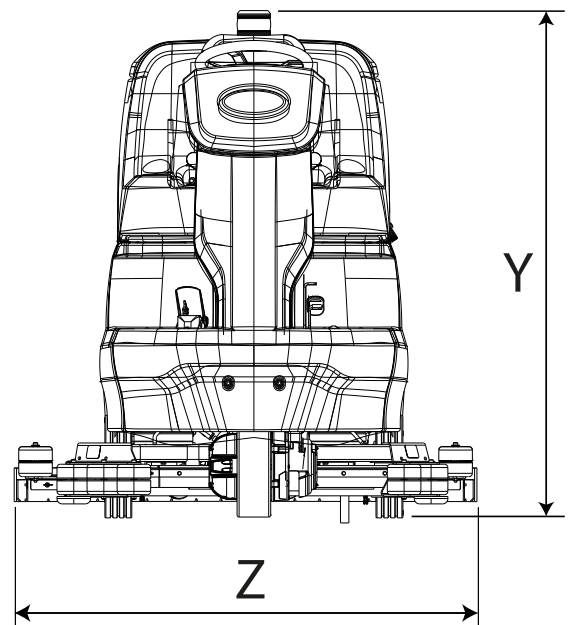
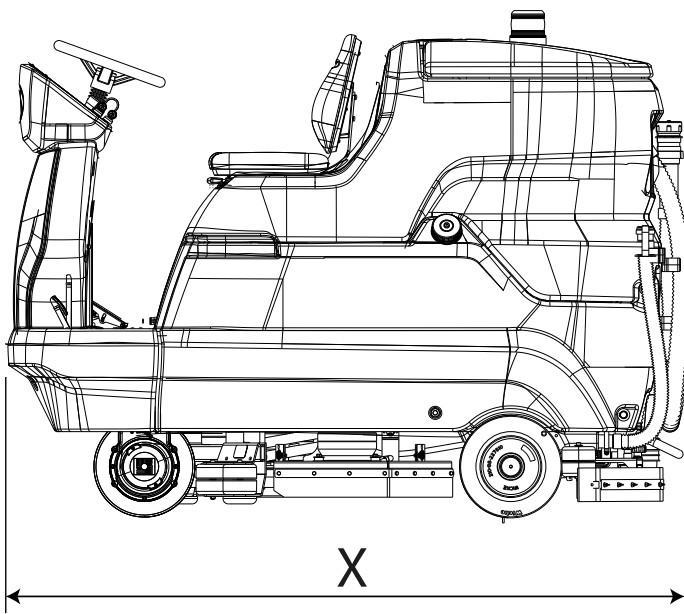

X-Y-Z: See "TECHNICAL SPECIFICATIONS" table

# GENERAL INFORMATION

## Purpose of this manual

This manual has been written by the Manufacturer and is an integral part of the [machine](#)<sup>1</sup>.

It defines the purpose for which the machine has been designed and constructed and contains all the information required by [operators](#)<sup>2</sup>.

In addition to this manual, which contains information for operators, other publications are available providing specific information for [maintenance personnel](#)<sup>3</sup>.

The terms “right” and “left”, “clockwise” and “anti-clockwise” refer to the forward movement of the machine.

Constant compliance with the instructions provided in this manual guarantees the safety of the operator and the machine, ensures low running costs and high quality results and extends the working life of the machine. Failure to follow these instructions may lead to injury to the operator or damage to the machine, floor and environment.

Consult the table of contents at the beginning of the manual to find the section of interest without delay.

**Although your machine may differ appreciably from the illustrations in this document, the correctness and validity of the instructions contained in this manual are guaranteed.**

## Identifying the machine

The nameplate provides the following information:

- Name of manufacturer.
- Model.
- Serial number.
- Year of manufacture.
- Power supply voltage (charging/supply value).
- Current intensity (maximum charge level, in line as far as possible with the value indicated by the battery manufacturer).
- Gross weight (GVW).
- IP degree of protection.
- Machine voltage (in average operating conditions).
- Machine power (in average operating conditions).
- Maximum negotiable gradient.

## Documentation provided with the machine

- User manual;
- CE certificate of conformity;

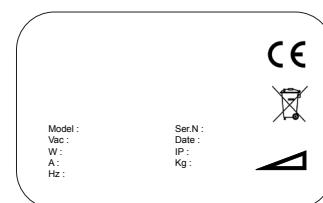

<sup>1</sup> The definition "machine" replaces the trade name covered by this manual.

<sup>2</sup> Persons responsible for using the machine without performing any operations requiring precise technical skills.

<sup>3</sup> Persons with experience, technical training and a knowledge of legislation and standards, able to perform all the necessary operations and to recognise and avoid possible risks in handling, installation, use and maintenance of this machine.

# TECHNICAL INFORMATION

## Main parts of the machine

### General description

This machine is a scrubber dryer for washing and drying flat, horizontal, smooth or moderately rough, even and obstacle free floors in civil and industrial premises.

The scrubber dryer spreads a solution of water and detergent in the correct concentration on the floor and then scrubs it to remove the dirt. With careful selection of the detergent and of the appropriate brushes (or abrasive disks), from the wide range of accessories available, the machine can be adapted to numerous combinations of floor types and dirt types.

The machine incorporates a wet vacuuming system which dries the floor as the surface is scrubbed clean. The drying action is produced by the vacuum motor, which generates a depression in the dirty water tank. The squeegee is connected to the tank, and collects the dirty water.

The main parts of the machine are listed below:

1. Dirty water tank.
2. Solution tank.
3. Control panel.
4. Head assembly.
5. Squeegee.
6. Dirty water tank drain hose.
7. Dirty water tank lid.
8. Driver seat.
9. Battery compartment.
10. Steering wheel.
11. Solution tank drain hose.
12. Squeegee hose.
13. Accelerator pedal.
14. Solution tank filler.
15. Service and parking brake pedal.
16. Side brushes (roller head model).
17. Side brush operating levers (roller head model).
18. Chem Dose tank (Chem Dose model).

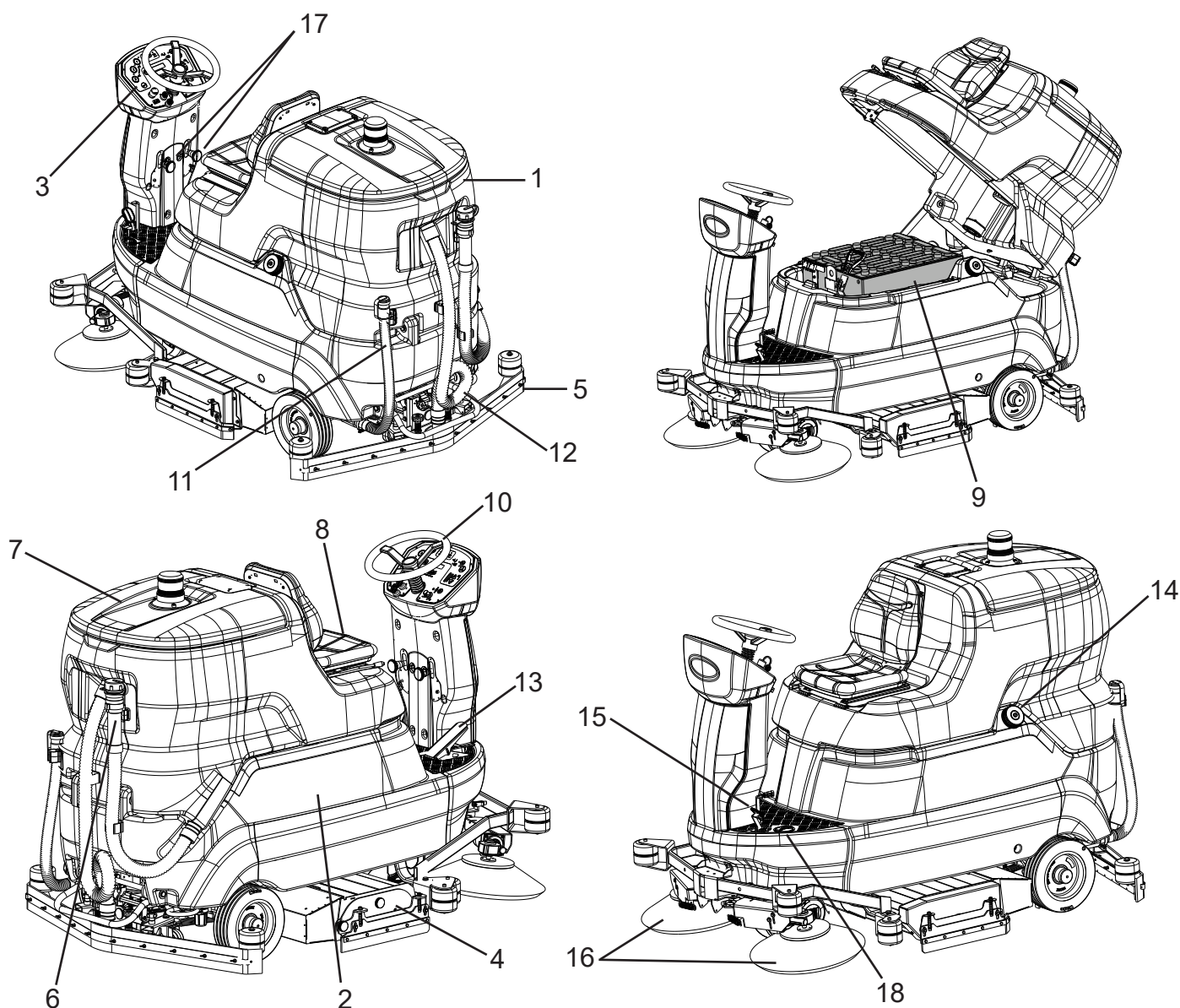

## Control panel

The machine has the following controls and indicator lights:

19. Attach/release brush button (disk brushes only) that enables the automatic brush attachment or release.
20. Main switch/Ignition switch: connects and disconnects electrical power to and from all functions of the machine.
21. Emergency stop button: acts as a safety device.
22. Speed potentiometer: regulates the maximum speed of the machine forward and in reverse.
23. Direction selector switch, determines movement of the machine forward or in reverse.
24. Buttons “+” and “-”, pressing these buttons determines the amount of flow delivered.
25. Display, showing: Battery voltage (Volt), Alarm codes and Hour counter.
26. Horn button.
27. Vacuum button: enables/disables the vacuum motor.
28. Brush button: enables/disables operation of the brush head.
29. Detergent tank level indicator: the LED comes on when there is no longer sufficient water in the detergent tank.
30. Dirty water tank level indicator: when the dirty water tank is full, the LED comes on.
31. Work program buttons (AUTOMATIC MACHINE OPERATION): buttons used to set the machine's work program:
  - 1, light intensity cleaning program for smooth floors, not excessively soiled.
  - 2, medium intensity cleaning program for smooth floors, noticeably soiled.
  - 3, high intensity cleaning program for rough floors (cement, etc.) soiled with stubborn dirt.
32. Drive wheel LED status indicator.
33. Programming button: press this button to scroll the parameters that can be set in the machine's software.

34. Chem Dose switch – enables/disables the device (Chem Dose model).

## Accessories

See list of recommended spare parts

- Bristle brushes/rollers: for washing delicate floors and polishing.
- Polypropylene brushes/rollers: for normal floor washing.
- Tynex brushes/rollers: for removing accumulated stubborn dirt on rugged floors.
- Drive disc: allows use of the different types of cleaning pad.
- WET and GEL batteries.
- Battery charger.

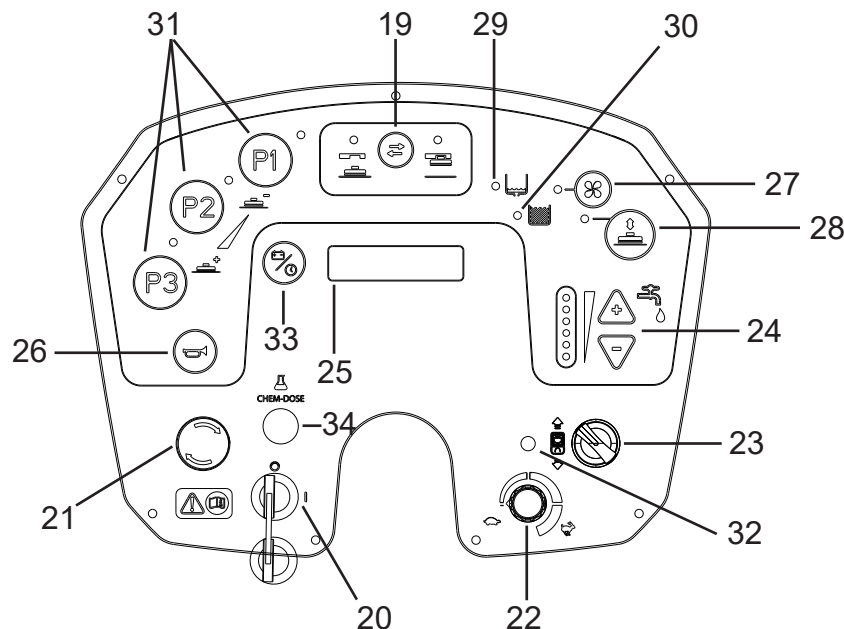

# **HANDLING AND INSTALLATION**

## **Lifting and transporting the palletized machine**

**! ATTENTION:** during all lifting operations, make sure the palletized machine is firmly secured to prevent it tipping over or being accidentally dropped.

The machine must be loaded onto/unloaded from vehicles in areas with adequate lighting.

The machine is packaged on a wooden pallet by the Manufacturer. It must be loaded on to the transporting vehicle using suitable equipment (see Directive 2006/42/EEC and subsequent amendments and/or additions). At destination, it must be unloaded using similar means.

The palletized body of the machine can be lifted only with the aid of a fork lift truck. Handle with care to avoid impact and ensure the machine is not overturned.

## **Inspection on delivery**

When the carrier delivers the machine, check that the packaging and the machine are both intact and undamaged. If the machine is damaged, make sure the carrier is aware of the damage and before accepting the goods, reserve the right (in writing) to request compensation for the damage.

## **Unpacking**

**! DANGER:** when unpacking the machine, the operator must wear suitable Personal Protection Equipment (gloves, eyewear, etc.) to limit the risk of injury.

When unpacking the machine, proceed as follows:

- Cut and remove the plastic straps using scissors or nippers;
- Remove the cardboard packaging;
- Remove the bags placed inside the battery compartment and check the contents: user manual; CE certificate of conformity; battery bridges with terminals; 1 x connector for battery charger; 2 x hex wrench;
- Remove the metal brackets securing the front/rear wheels and the machine chassis to the pallet base.

- Release the parking brake by pressing the lever next to the pedal.

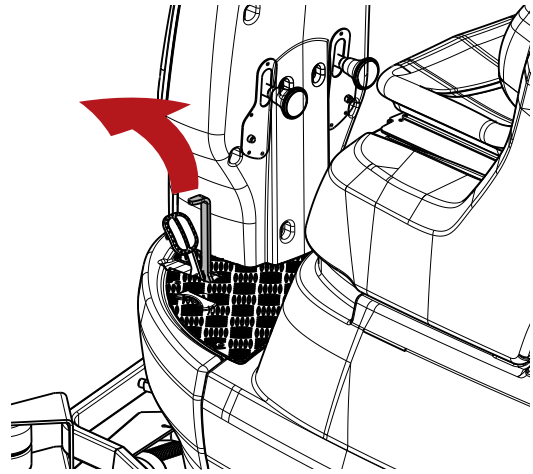

- Before unpacking the machine, check that the head assembly is raised.
- Using a ramp, push the machine off the pallet in the reversing direction. The machine must not be lifted.

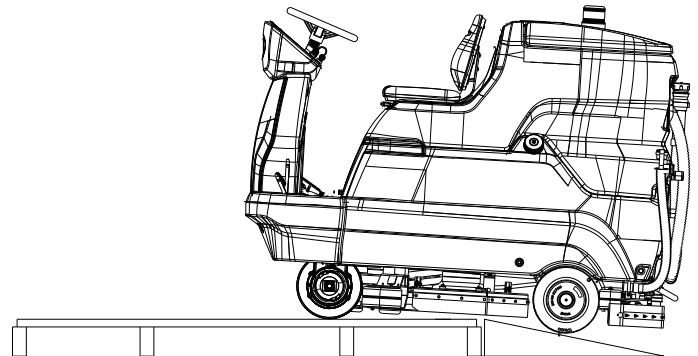

- Remove the brushes from their packaging.
- Clean the outside of the machine, taking care to observe safety regulations.

Once the machine is clear of the packaging, proceed to install the batteries (refer to section “**Batteries: installation and connection**”).

The various items of packaging can be kept, if so desired, as these can be reused to protect the machine in the event of it being moved to a different site or sent to a repair workshop.

If not retained, the packaging must be disposed of in compliance with current regulations.

## Batteries

**! ATTENTION: do not use NON-rechargeable batteries**

Two different types of battery can be installed on these machines:

Leak-proof tubular batteries (WET): the electrolyte level must be checked regularly.

Sealed batteries (GEL or AGM): this type of battery requires no maintenance.

The technical specifications of the battery must correspond to those listed in the section on the “**Technical specifications**” of the machine. The use of heavier batteries could seriously jeopardize manoeuvrability and lead to the drive motor overheating. Lighter batteries of lower capacity, on the other hand, will need to be charged more frequently.

## Machine Battery Selection Setting

**! ATTENTION: where machines are shipped without batteries, the machine is factory set for WET lead-acid batteries as the default configuration.**

**Depending on the type of battery selected (WET lead-acid or sealed GEL / AGM), the battery parameters of the machine MUST be adjusted if different from the factory setting.**

**! NOTICE**

**Enter the type of battery installed in the machine software settings.**

Follow the instructions below to adjust the machine logic settings for the type of battery installed:

- Switch the machine off by turning the key.

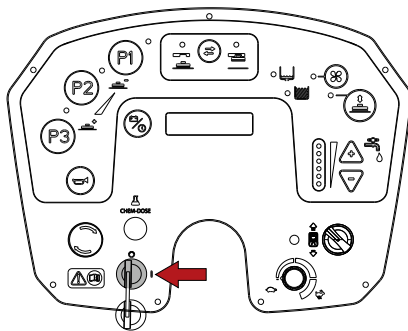

- Press buttons "1 and 3" at the same time, then switch the machine on by turning the ignition key.

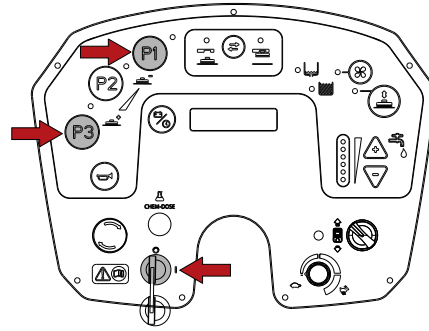

- Press the programming button three times, the message “GEL battery” will appear on the display.

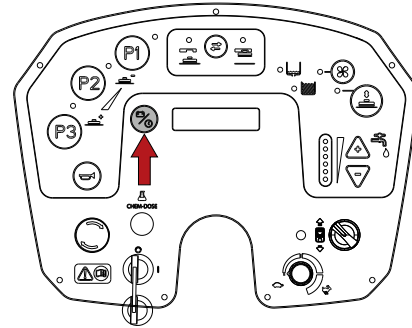

- Select the type of batteries installed using the "+" or "-" button: “ACID battery” or “GEL battery”.

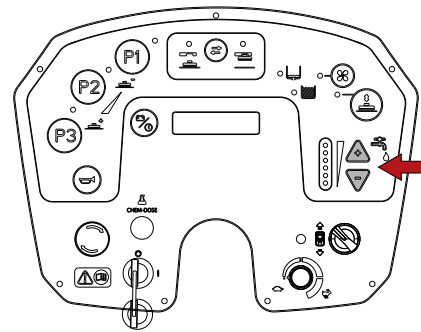

- Store the parameter by pressing and holding the programming button until the display shows the battery voltage value.

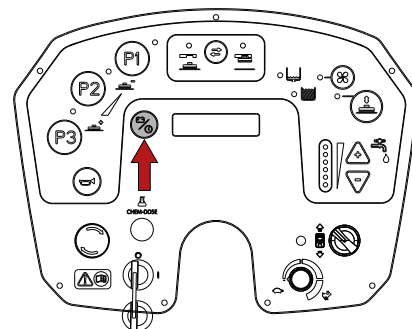

## WET batteries, preparation:

**!** **DANGER:** Installation and connection/removal of the batteries must be entrusted to a IP CLEANING-approved service technician (referred to hereinafter as skilled technician).

**!** **DANGER:** during installation of the batteries or any type of battery maintenance, the skilled technician must wear the Personal Protective Equipment (gloves, eyewear, overalls, etc.) needed to limit the risk of accidents. Keep away from naked flames, do not short circuit the battery poles, do not generate sparks and do not smoke.

**!** **DANGER:** in the event of battery fluid leakage, do not touch the fluid and observe the following precautions:  
Contact with the skin can cause irritation; wash with soap and water.  
Inhalation of vapours can cause irritation to the airways; stay out in the open air and consult a doctor.  
Contact with eyes can cause irritation, wash eyes immediately and thoroughly with water for at least 15 minutes; consult a doctor.

(WET) Batteries are normally supplied filled with acid and ready for use.

If the batteries in use are dry charged, they must be activated before being installed in the machine. Proceed as follows:

Remove the caps and fill all elements with sulphuric acid solution specific for batteries until the plates are completely covered (this requires at least a couple of passes for each element). IF IN DOUBT, CONTACT YOUR LOCAL DEALER.

Leave the batteries to stand for 4-5 hours to allow air bubbles to come to the surface and the plates to absorb the electrolyte.

Make sure the level of electrolyte is still above the plates and if necessary top up with sulphuric acid solution; Close the caps.

Install the batteries in the machine (following the procedure described below).

Charge the batteries before starting up the machine for the first time. Follow the instructions in the **"Battery charging"** section.

## Batteries: installation and connection

**!** **DANGER:** during installation of the batteries or any type of battery maintenance, the skilled technician must wear the Personal Protective Equipment (gloves, eyewear, overalls, etc.) needed to limit the risk of accidents. Keep away from naked flames, do not short circuit the battery poles, do not generate sparks and do not smoke.

**!** **DANGER:** in the event of battery fluid leakage, do not touch the fluid and observe the following precautions:  
Contact with the skin can cause irritation; wash with soap and water.  
Inhalation of vapours can cause irritation to the airways; stay out in the open air and consult a doctor.  
Contact with eyes can cause irritation, wash eyes immediately and thoroughly with water for at least 15 minutes; consult a doctor.

**!** **ATTENTION:** the operation of installing and connecting the batteries must be carried out by qualified personnel.

**!** **ATTENTION:** before carrying out the operations described below, stop on a flat and level surface, switch off the machine, remove the ignition key and apply the parking brake.

**!** **ATTENTION:** before carrying out the operations described below, empty the dirty water tank, referring to the section "Emptying the dirty water tank".

**!** **DANGER:** Make certain that the terminals marked with a "+" are connected to the positive poles of the battery. Do not check the battery charge by sparking.

- Tilt the operator seat toward the steering wheel.

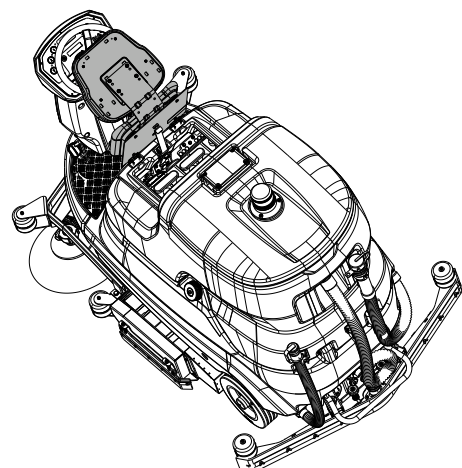

- Unlock the dirty water tank from the solution tank by pulling the knob as illustrated.

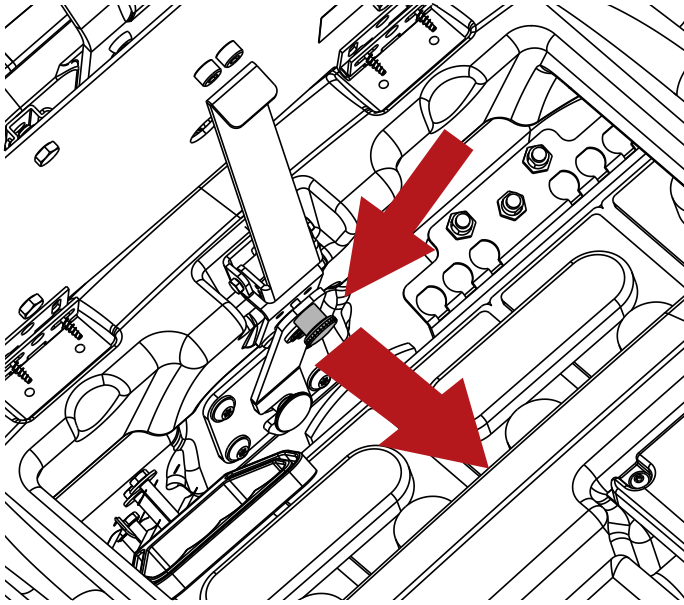

- Rotate the stop, and release the knob so that it locates in the retaining hole.

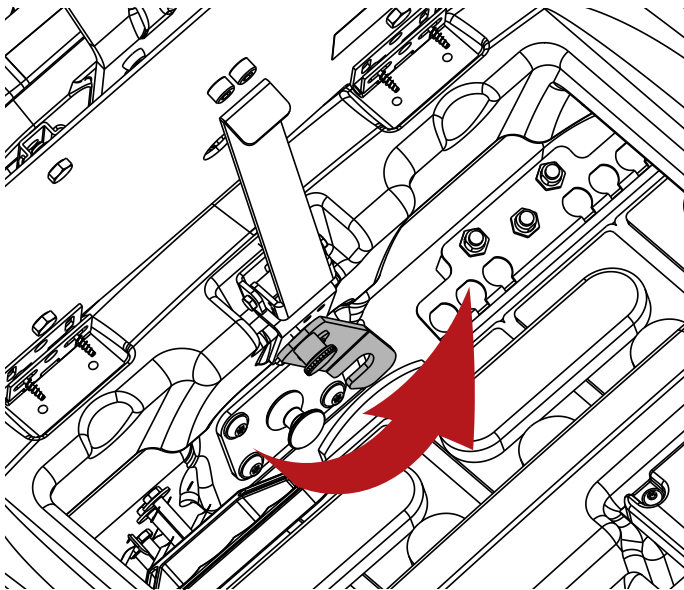

- Return the operator seat to the working position.
- Tilt the dirty water tank backwards.
- Place the batteries in the battery compartment as indicated on the label under the seat frame.
- Connect the wiring terminals to the battery poles, tighten and smear with Vaseline.
- Reinstall the dirty water tank in the working position, locking it to the solution tank by means of the stop.
- When using the machine, follow the instructions below.

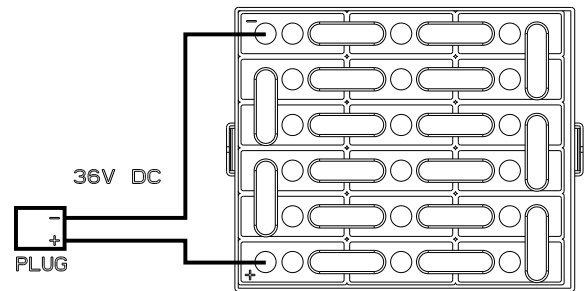
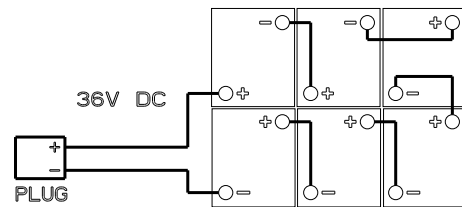
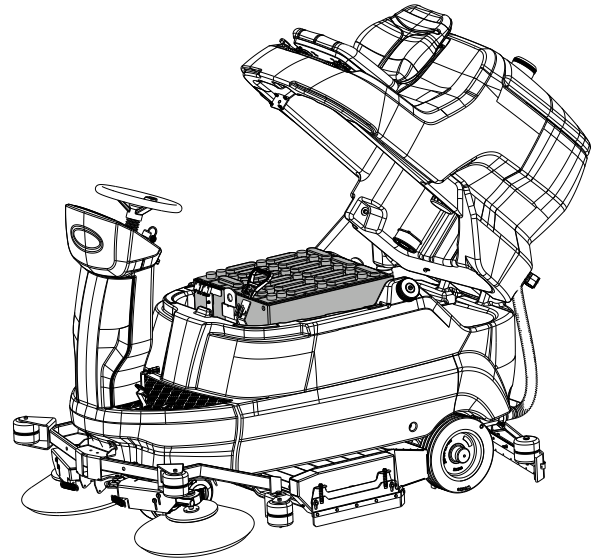

### Choosing the battery charger

**! DANGER:** use a battery charger with CE marking that is in compliance with product standard (EN 60335-2-29), equipped with double insulation or reinforced insulation between input and output and with SELV type output circuit.

**! ATTENTION:** check that the battery charger is compatible with the batteries being charged.

Tubular lead-acid (WET) batteries: an electronic battery charger is recommended, but consult the manufacturer and the battery charger manual to confirm the suitability of the external battery charger.

Gel or AGM batteries: use a charger intended specifically for the type of battery.



## Preparing the battery charger

**! ATTENTION:** this procedure must be carried out only by an authorized technician.

When using a battery charger not provided with the machine, it must be fitted with the connector included in the machine equipment package.

The connector supplied for the external battery charger is suitable for cables with maximum cross-section 16 mm<sup>2</sup>

Proceed as follows to fit the connector:

- Remove around 13 mm of the protective sheath from the red and black conductors of the battery charger cable;
- Attach the ends to the contacts of the connector and squeeze forcibly with suitable crimping pliers;
- Make certain the polarity is correct (red + black -) when attaching the wires to the connector.

## Battery charger settings

**! ATTENTION:** where machines are shipped without batteries, the machine is factory set for WET batteries as the default configuration.

Make certain that the battery charger is correctly set up, according to the type of batteries installed.

Failure to observe these instructions could result in damage to the battery. Depending on the type of battery selected (WET or GEL - AGM), the battery parameters of the machine **MUST** be adjusted if different from the factory setting. See section "Setting the battery type on the machine" for directions.

## Fitting the squeegee

**! ATTENTION:** before carrying out the operations described below, stop on a flat and level surface, switch off the machine, remove the ignition key and apply the parking brake.

- Loosen the two knobs.
- Locate the two threaded pins in the slots on the support.

- Connect the vacuum hose to the squeegee, bending it to the position as illustrated.

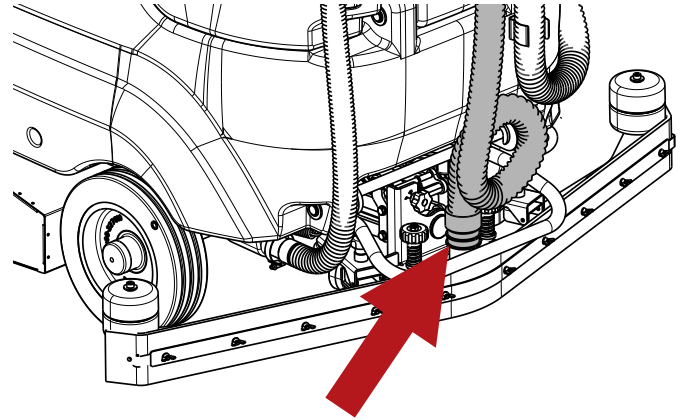

- Tighten the two knobs.

The position of the squeegee is factory-set. Should the squeegee blade require adjustment, refer to the section "Squeegee adjustment".

## Squeegee adjustment

**! ATTENTION:** before carrying out the operations described below, stop on a flat and level surface, switch off the machine, remove the ignition key and apply the parking brake.

The squeegee blades scrape the film of water and detergent from the floor and prepare the way for perfect drying. With time, and the constant wiping action, the edge of the blade in contact with the floor becomes rounded and cracked, diminishing its drying efficiency, so that ultimately a new blade is required. The state of wear should be checked frequently.

To ensure faultless drying, the squeegee must be adjusted as illustrated, in such a way that the edge of the rear blade deflects during operation by about 45° relative to the floor, at all points along its length.

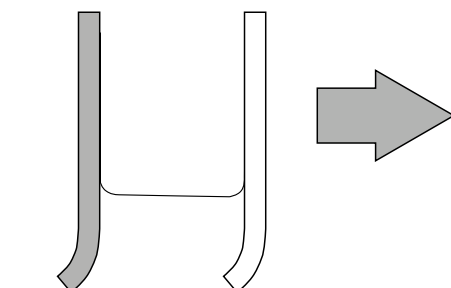
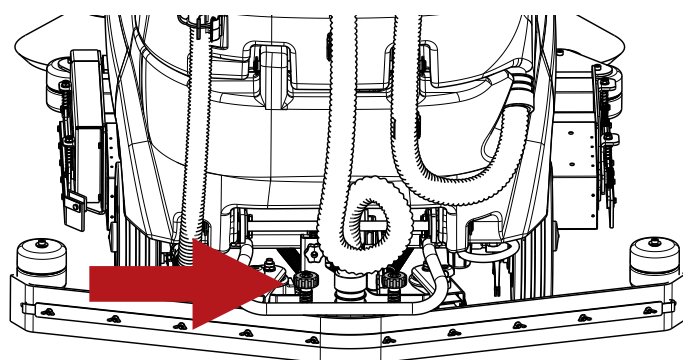

The angle of the blades can be adjusted by turning the knob positioned above the squeegee.

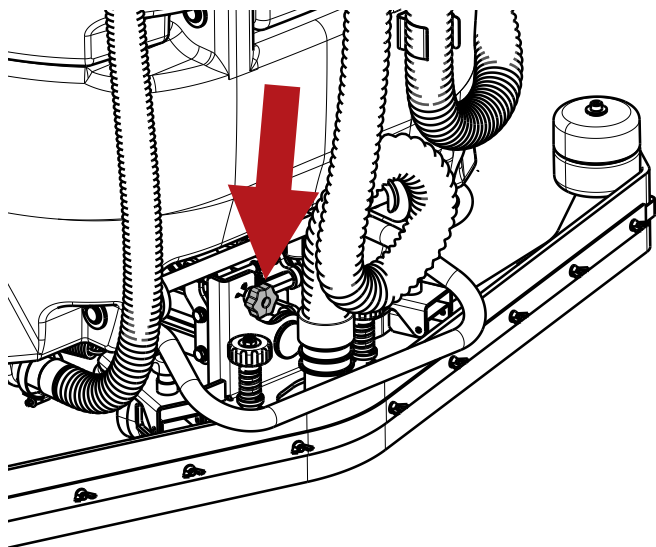

Similarly, the height of the squeegee can be adjusted by raising or lowering the two wheels positioned in front of / behind the squeegee, turning the relative knobs.

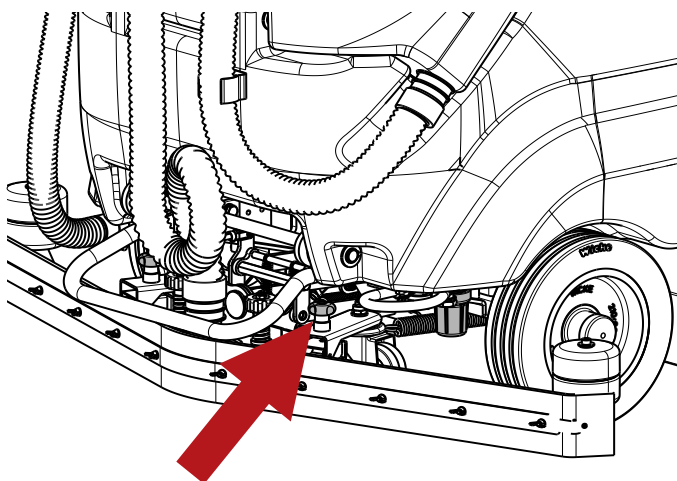

### Installation of Brush / Drive disc

**! ATTENTION:** before carrying out the operations described below, stop on a flat and level surface, switch off the machine, remove the ignition key and apply the parking brake.

**! DANGER:** during installation, the operator must wear personal protective equipment (gloves, eyewear, overalls, etc.) needed to limit the risk of accidents.

**! ATTENZIONE:** before installing the Drive disc on the machine, make certain that the Pad is attached to the disc.

### Installation of Brush (or Drive disc)

- Raise the access flaps on both sides and position the brushes underneath the housing, making certain that they rest against the locating stops to align them with the coupling assembly.

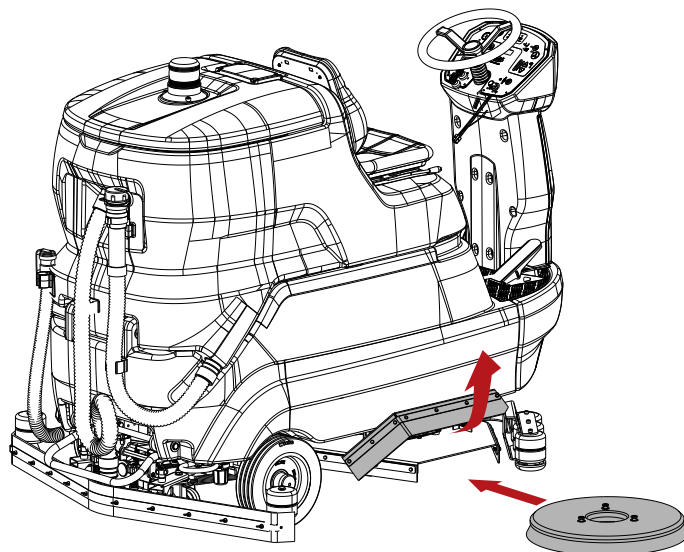

- Turn the ignition key to switch the machine on.

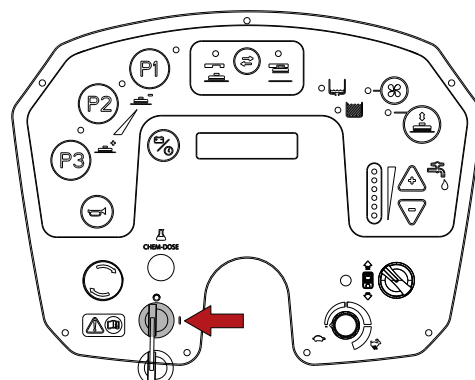
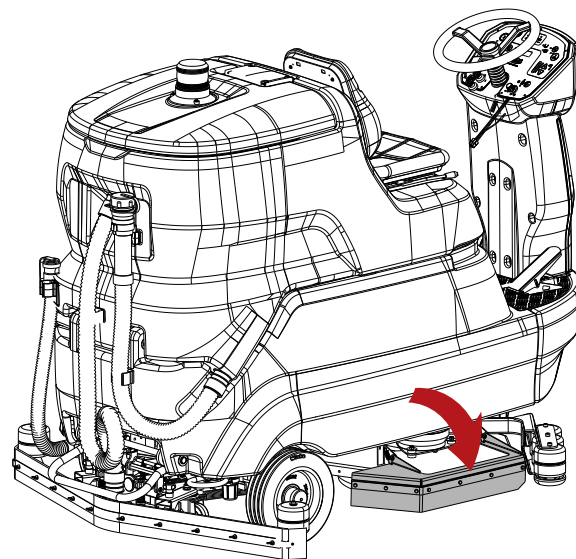

- Press the brush coupling/release button, the machine will first perform a release operation, which immediately enables the coupling operation; now the machine is ready for the coupling step, which can be accomplished by pressing the brush coupling and release button a second time.

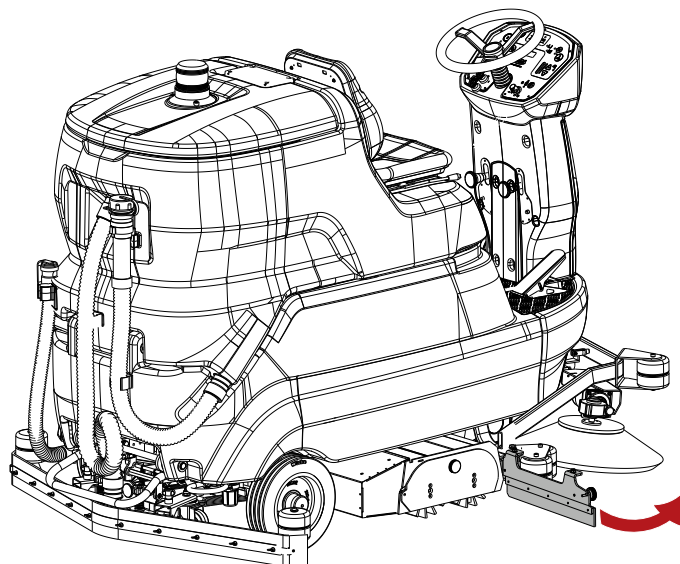
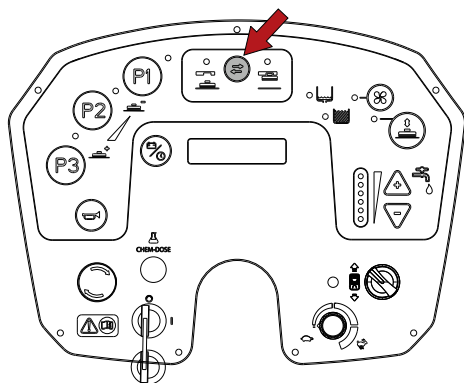

- Remove the cover from the brush compartment by unscrewing the knob.

### Installation of brushes (roller head model).

**! ATTENTION:** before carrying out the operations described below, stop on a flat and level surface, switch off the machine, remove the ignition key and apply the parking brake.

**! DANGER:** during installation, the operator must wear personal protective equipment (gloves, eyewear, overalls, etc.) needed to limit the risk of accidents.

Assembly:

- Open the right hand side flap by unscrewing the knob.

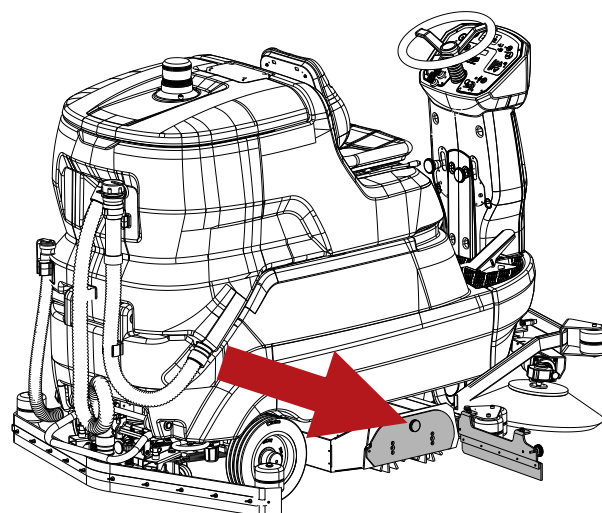

- Position the roller brushes in the two compartments, making certain that the guide pin on the opposite side is correctly located.

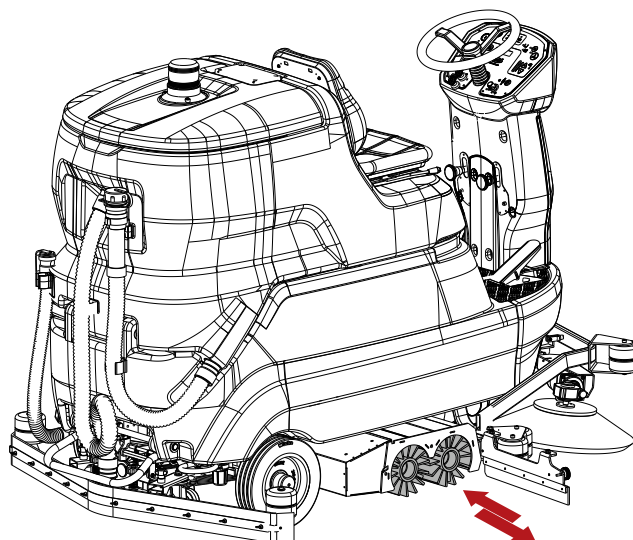
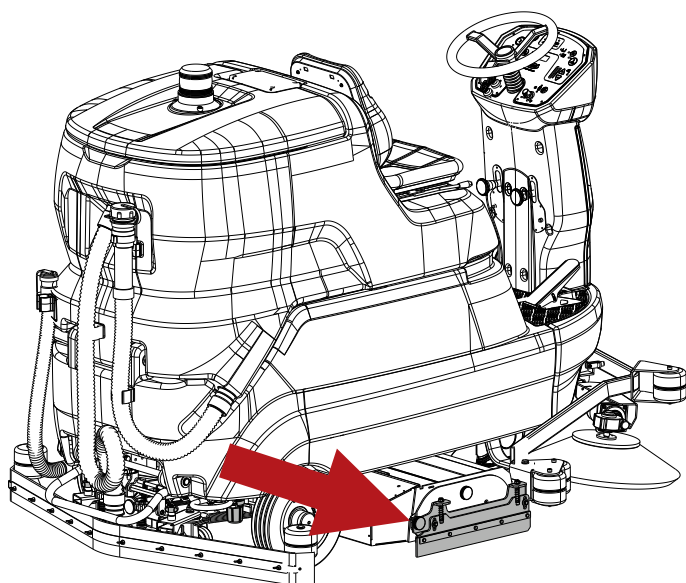

- Refit the cover and close the side flap.

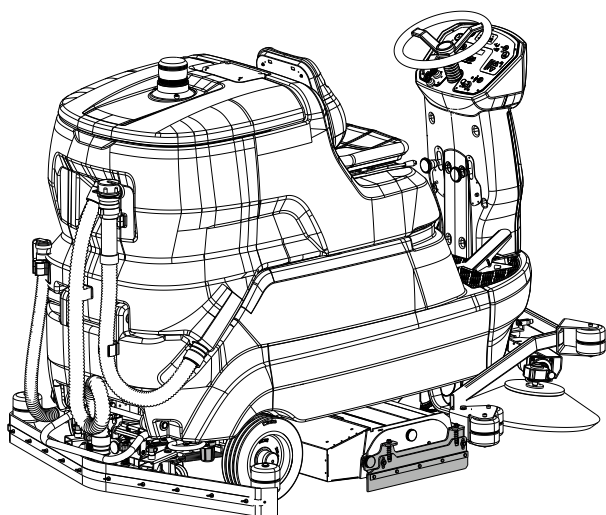

Disassembly:

- Repeat the steps described above in reverse order.

### Installation of side brushes (roller head model).

**! ATTENTION:** before carrying out the operations described below, stop on a flat and level surface, switch off the machine, remove the ignition key and apply the parking brake.



**! DANGER:** during installation, the operator must wear personal protective equipment (gloves, eyewear, overalls, etc.) needed to limit the risk of accidents.

Assembly:

- Undo the screw on the motor shaft.
- Check that the drive key is located in the keyway of the motor shaft.
- Position the brush complete with flange on the motor shaft.
- Retighten the clamp screw.

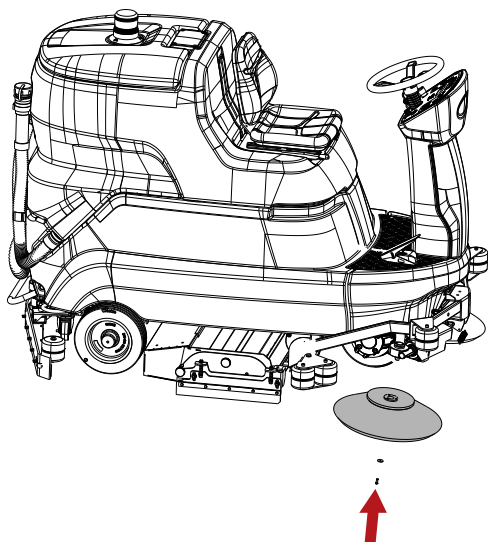

Disassembly:

- Repeat the steps described above in reverse order.

### Filling the detergent tank

**! ATTENTION:** before carrying out the operations described below, stop on a flat and level surface, switch off the machine, remove the ignition key and apply the parking brake.

**! ATTENTION:** when using the Chem Dose device (Chem Dose model), the solution tank must be filled with **WATER ONLY**, at a temperature of between +4 °C / 39.2 °F and 55 °C / 131 °F.

Do **NOT** put detergent solution into the tank.



**! DANGER:** flammable liquids can be the cause of explosion or fire. Do not put flammable liquids into the tank.

**! ATTENTION:** fill the tank with detergent at a temperature of between +4 °C / 39.2 °F and 55 °C / 131 °F.

**! ATTENTION:** the machine has been designed for use with detergents supplied or recommended by the Manufacturer. The use of other detergents or chemicals can affect the safety of the machine.

**! ATTENTION:** the selected detergent should be utilized rationally, in accordance with the directions given on the packaging of the product.

**! ATTENTION:** select a detergent from the range of recommended products that is most suitable for the washing operation in hand, and dilute with water following the instructions on the pack or in the catalogue.

Unscrew the cap and fill the tank from the appropriate opening,

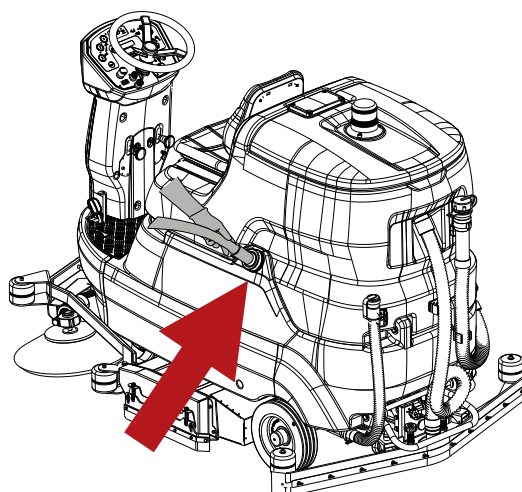

or use the hose with ACQUA-STOP fill system (model with ACQUA-STOP). Once the quick coupling hose is connected to the machine, this device allows the tank to be filled without the presence of the operator. Dispensing will be stopped automatically when the tank is filled.

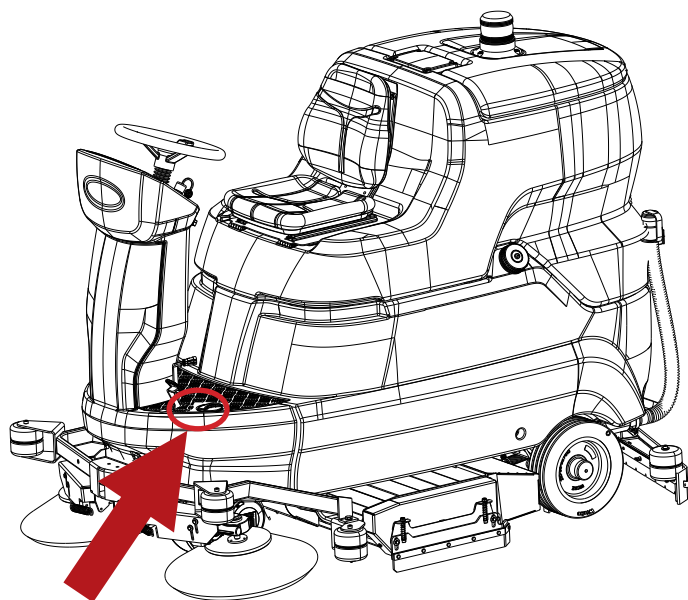
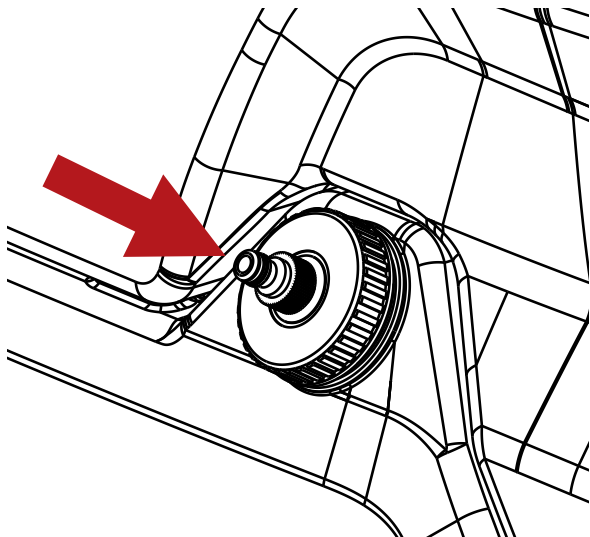

### Select the percentage dilution of the detergent – (Chem Dose model).

Regulate the detergent mixture to be supplied to the brushes as follows:

- Turn the ignition key to switch the machine on.

### Chem Dose – (Chem Dose model)

**! DANGER:** flammable liquids can be the cause of explosion or fire. Do not use flammable liquids.

**! ATTENTION:** before carrying out the operations described below, stop on a flat and level surface, switch off the machine, remove the ignition key and apply the parking brake.

**! ATTENTION:** the machine has been designed for use with detergents supplied or recommended by the Manufacturer. The use of other detergents or chemicals can affect the safety of the machine.

**! ATTENTION:** when using the Chem Dose device, the solution tank must be filled with **WATER ONLY**, at a temperature of between +4 °C / 39.2 °F and 55 °C / 131 °F.

Do **NOT** put detergent solution into the tank.

Using the Chem Dose scrubbing system (Chem Dose model), the detergent can be managed separately from the solution tank: it can be activated or deactivated at any given moment, and is able to mix the detergent with water with a percentage accuracy of between 0.5% and 10%. Fill the tank with low-foam detergent at a suitable concentration.

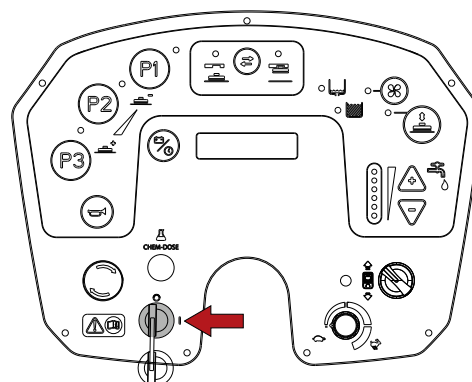

- Press and hold the programming button until the selected language appears on the display, then release.

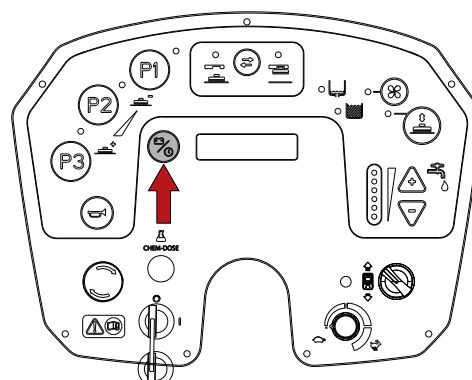

- Press the programming button until the parameter "Chemical flow rate" appears.

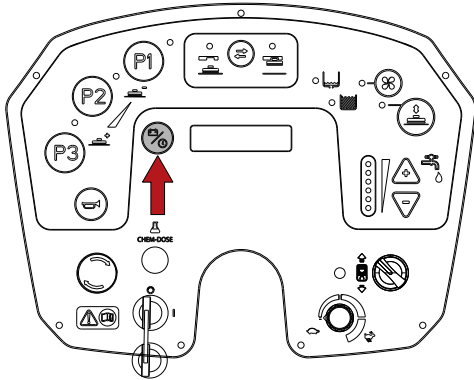

- Press the '+' and '-' buttons to set the detergent percentage, minimum 0.5%, maximum 10%.



- To store the changes and exit, press and hold the programming button until the display shows the battery voltage.

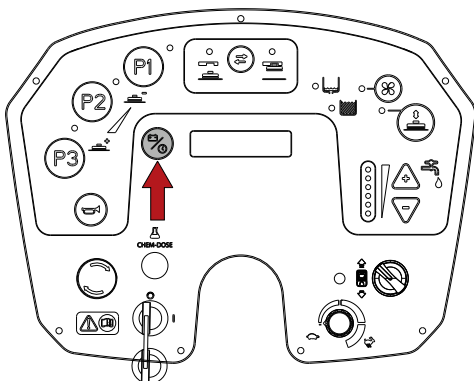

# PRACTICAL GUIDE FOR THE OPERATOR

## Clothing and equipment

Wear safety shoes with non-slip soles.  
Wear protective eyewear or visor and safety garments.  
Depending on the surface being cleaned and on the environment, the protective measures necessary for atomized sprays include respiratory masks with class FFP2 or equivalent or higher protection.

## Before starting the machine

Clear away larger items of refuse before washing. Pick up any pieces of wire, tape, string and similar items that could become entangled around the brushes.  
Before washing is commenced, sweep the area so as to avoid the appearance of streaks on the floor.

## Preparing the machine for work

Proceed as follows before starting work:

- Check that the batteries are fully charged, and if not, carry out the recharging procedure: when undertaking this operation, refer to the section “**Charging the batteries**”.
- Make certain that the dirty water tank is empty, and if not, empty it, referring to the section “**Emptying the dirty water tank**”.
- Make certain that the solution tank is full, and if not, proceed to fill it, referring to the section “**Filling the water/detergent tank**”.
- Check that the Chem Dose tank (Chem Dose model) is full, and if not, fill it up, referring to the section “**Chem Dose - (Chem Dose model)**”.
- Make sure the solution flow tap is turned on.

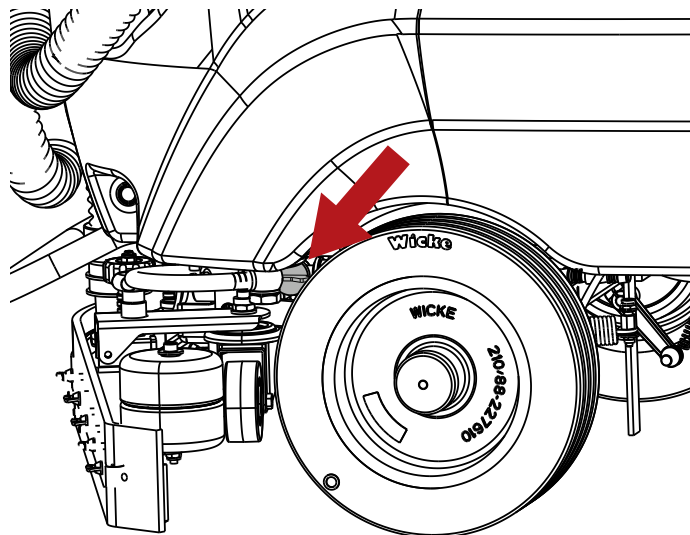

- On machines equipped with Chem Dose (Chem Dose model), make certain that the detergent flow valve is open.

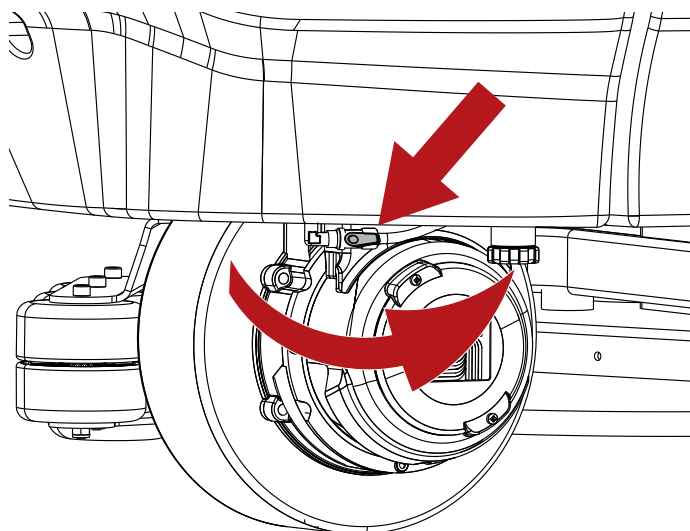

### ! NOTICE

For maximum comfort when using the machine, the position of the operator seat can be adjusted.

## Working

**! ATTENTION:** do not use the machine without first reading the operating and maintenance manual.

### ! NOTICE

Releasing the accelerator pedal, all of the functions are stopped automatically within 5 seconds (Power Off-On); in this standby condition, the indicator light corresponding to the selected program will blink. To reactivate the functions, simply move the machine forward, without deselecting the program (Power Off-On).

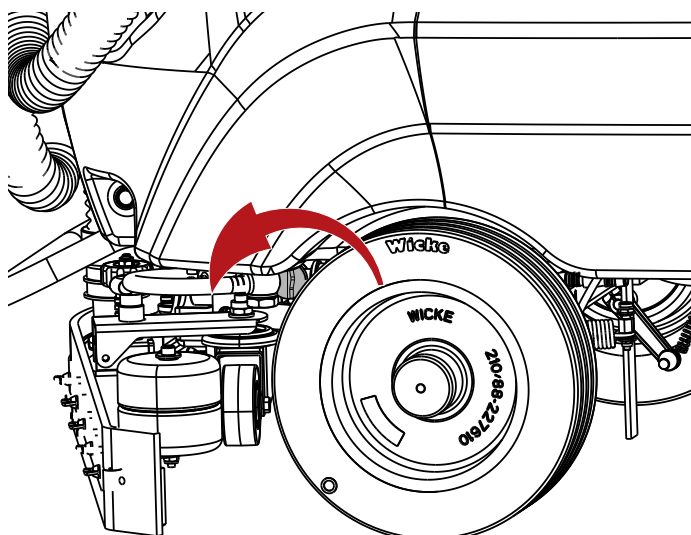

## ! NOTICE

Whenever the machine moves in reverse, the squeegee is raised automatically to prevent any possible damage.



**! DANGER:** Never use the machine to clean up flammable or explosive liquids (e.g. petrol, fuel oil, etc.), acids or solvents (e.g. paint thinners, acetone etc.) even if diluted.

- Sit on the seat.
- Turn the ignition key to switch the machine on.

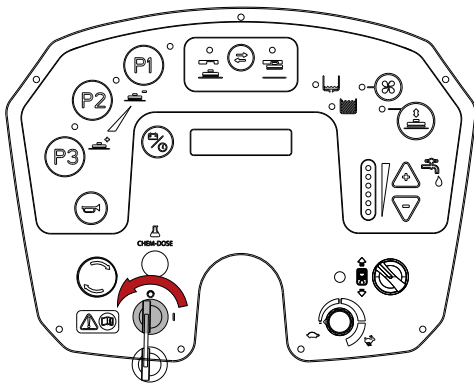

- Use the drive selector to select forward drive.

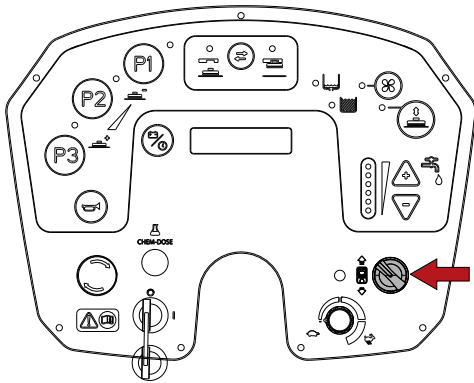

- **Roller head model:** lower the side brushes by pulling and lowering the levers. The brush motors will come into operation only when the brushes are completely lowered.

## ! NOTICE

A resettable fuse is fitted beneath each of the side brush operating levers. In the event that a side brush should stop working, press the button to reset the fuse.

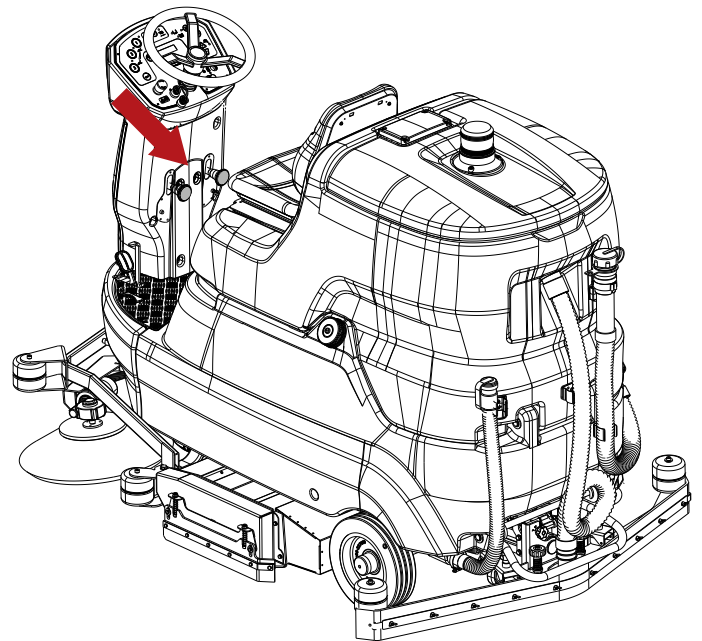

- From the three available programs, select the one most suitable for the work being performed; by pressing these buttons, all of the functions relating to the selected program will be activated (brush motor, vacuum motor):
  - 1, light intensity cleaning program for smooth floors, not excessively soiled.
  - 2, medium intensity cleaning program for smooth floors, noticeably soiled.
  - 3, high intensity cleaning program for rough floors (cement, etc.) soiled with stubborn dirt.

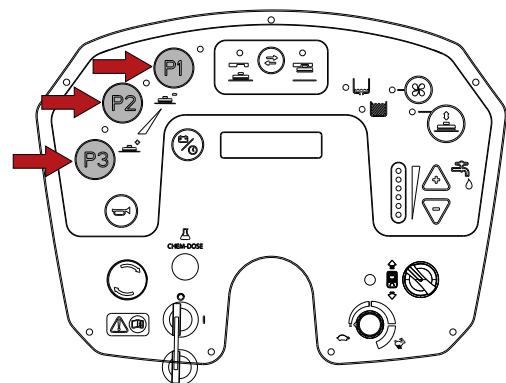

To change from one program to another, first deselect the current program, then select the new program.



- Select the most suitable solution flow according to the type of washing operation, using the “+” and “-” buttons; Led indicators will light up to display the quantity.

**! NOTICE**

**Intended as a safety feature, the accelerator pedal must be pressed slowly and gently at first, so as to set the machine in motion.**

- The maximum operating speed can be set by turning the speed potentiometer.

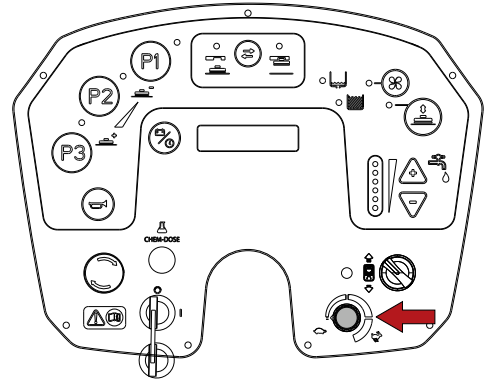
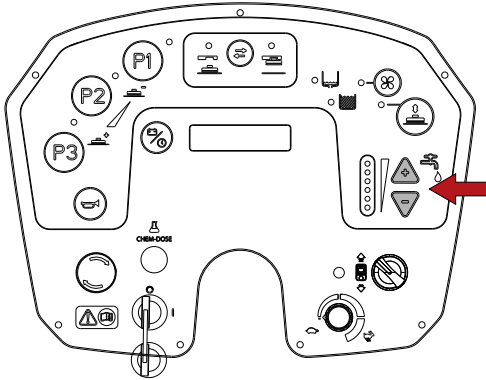

- **Chem Dose model**, press the switch to turn on the device. To change the percentage dilution of the detergent (Chem Dose model), refer to the section “**Selecting the percentage dilution of the detergent (Chem Dose model)**”.

To stop the machine, release the accelerator pedal and depress the brake pedal; refer to the section “**Service brake and parking brake**”.

**! NOTICE**

**Roller head model:** at the end of cleaning operations, raise the side brushes.

**Service brake and parking brake**

To apply the service brake, depress the brake pedal and at the same time operate the parking brake release lever.

**! ATTENTION:** when using the Chem Dose device, the solution tank must be filled with **WATER ONLY**, at a temperature of between **+4 °C / 39.2 °F** and **55 °C / 131 °F**.

**Do NOT** put detergent solution into the tank.

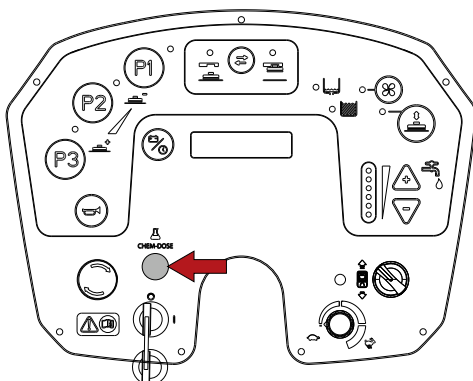

- Start cleaning, turning the steering wheel by hand and depressing the accelerator pedal.

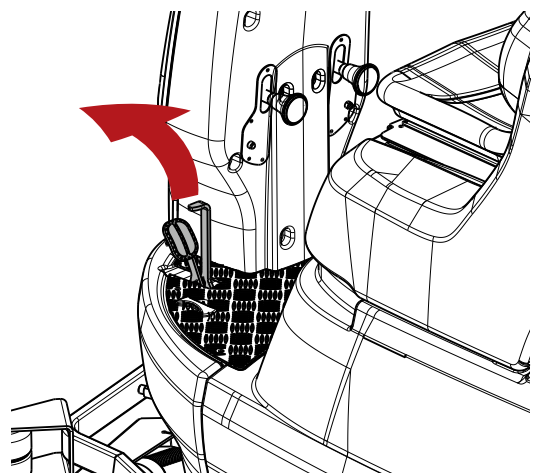

To apply the parking brake, depress the brake pedal fully.

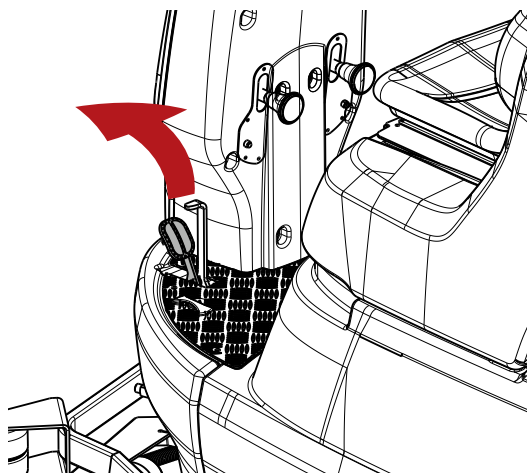

## “Double Scrubbing” Method

In cases where floors are soiled with particularly stubborn dirt, scrubbing and drying operations can be performed in two separate stages.

Prewash with brushes or pads:

- Turn the ignition key to switch the machine on.

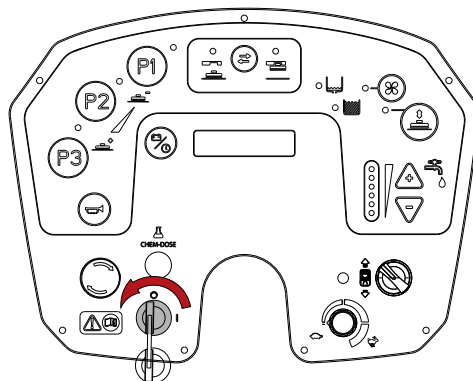

- Press the brush button.

To release the parking brake, press the lever next to the pedal.

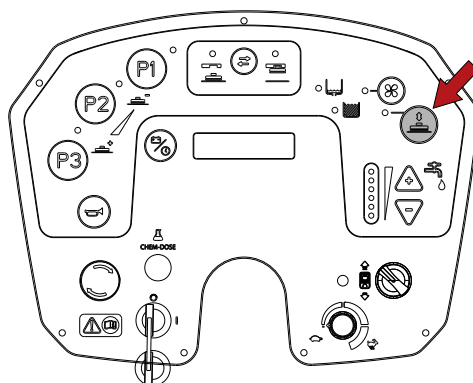
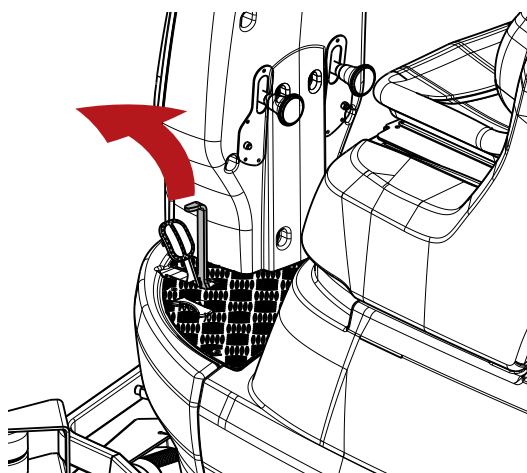

- Set the detergent solution flow.

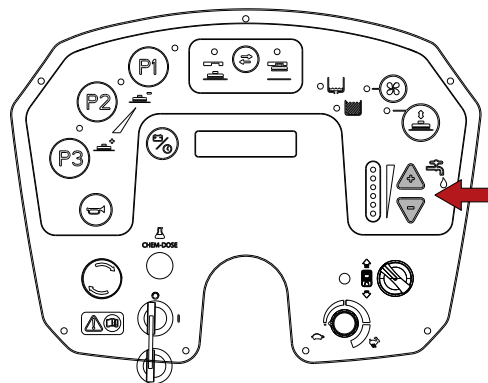

- When scrubbing particularly dirty areas, give the detergent sufficient time to perform its chemical action of detaching and suspending the dirt in the film of water, and allow the brushes time to exert an effective mechanical action.

#### Drying:

- Press the vacuum motor button: the vacuum fan switches on and the squeegee is lowered

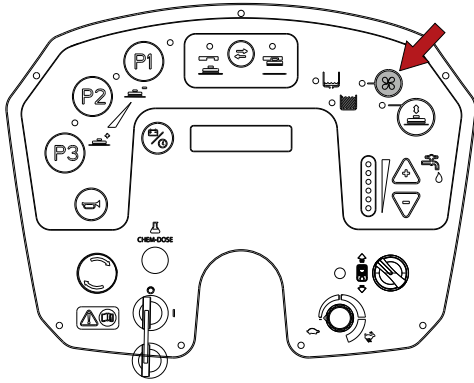

- Pass the machine over the area washed previously: the effect will be to produce a deep cleansing action, with the result that subsequent routine maintenance operations will take much less time.

#### Picking up water (without washing)

The machine can be used to mop up spills of water or NON-flammable liquids, without any cleaning action. Press the vacuum motor button: the squeegee is lowered and the vacuum fan comes into operation.

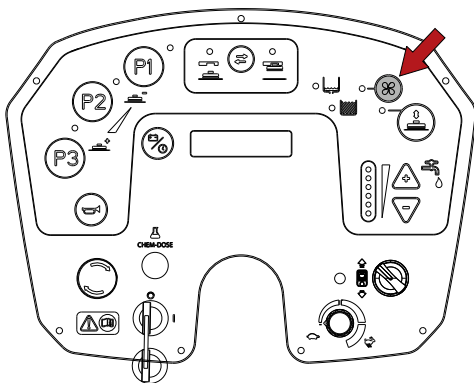

Proceed to pick up the liquids.

#### During operation of the machine

- Keep the cleaning passes as straight as possible.
- Overlap successive cleaning passes by a few centimetres.
- Adjust the ground speed of the machine, the contact pressure of the brush and the flow of detergent to suit the type of cleaning. Use the minimum available settings, as far as practically possible, for the brush pressure and detergent solution flow.
- Check the battery charge indicator to ensure there will be sufficient power for completion of the cleaning operation.
- Check the detergent solution level indicator to ensure that the relative tank is not empty.
- Check the dirty water level indicator to ensure that the relative tank is not full.
- Keep the machine moving forward to prevent damage to floor finishes.

**! ATTENTION: the brush head and squeegee will be raised automatically raise to the transport position if the key is turned to the "0" position. Stay clear of moving parts to avoid the potential risk of crushing.**

**! ATTENTION: do not attempt to clean surfaces on slopes or gradients steeper than indicated on the machine data plate.**

**! ATTENTION: Do not operate the machine on slopes or gradients steeper than indicated on the data plate.**

**! ATTENTION: When using the machine on gentle gradients, do not move transversely across the slope, but keep the machine on a line parallel to the direction of the incline, manoeuvring carefully and without making U-turns.**

#### Emergency stop button

In the event of emergency, this button isolates the machine from its power source.

To cut off the power supply, push the button in.

To restart the machine, rotate the button and cycle the key.

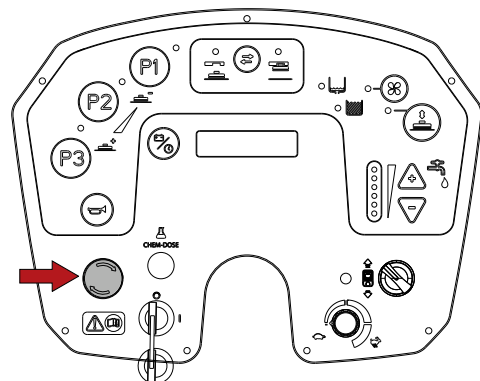

## Detergent solution tank empty indicator

When the solution tank is empty, the indicator lights up and all cleaning functions are inhibited. The detergent solution tank must now be filled: when carrying out this operation, refer to the section “Filling the detergent solution tank”.

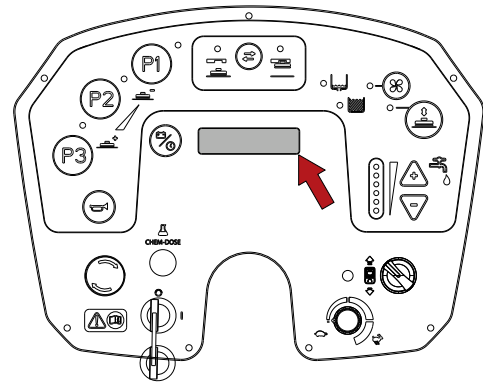
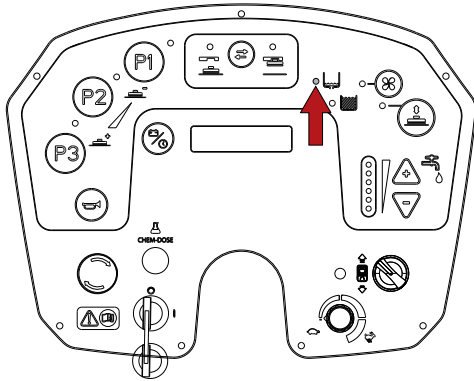

## Emptying the dirty water tank

**! ATTENTION:** before carrying out the operations described below, stop on a flat and level surface, switch off the machine, remove the ignition key and apply the parking brake.

When cleaning operations have been completed, empty the dirty water tank.

If the tank is full, the indicator lights up and the cleaning functions of the machine will be inhibited; after a few seconds, the vacuum motor also shuts down. At this point the machine must be brought to a halt and the dirty water tank emptied, following the instructions indicated below:

- Take the machine to the designated service area.
- Unhook the hose from the clip.
- Empty the tank by way of the drain hose: keep the hose raised initially and remove the plug, then lower the hose gently and position it over the drain outlet.
- Rinse the tank with clean water.
- Rinse the float of the dirty water tank, referring to the directions given in the section “Cleaning the dirty water tank sensor”.
- Refit the plug to the drain hose and reattach the hose to the clip.

## Dirty water tank full indicator

When the dirty water tank is full, the indicator lights up and all cleaning functions are inhibited. The dirty water tank must now be emptied: when carrying out this operation, refer to the section “Emptying the dirty water tank”.

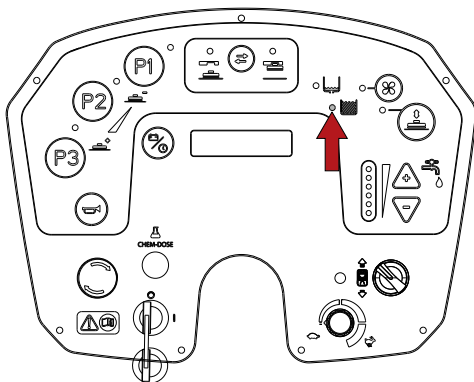

## Battery charge indicator

The display indicates the battery voltage: when this drops below a specific level the cleaning functions will be disabled, whereas traction remains enabled; proceed with the recharge, referring to the directions given in the section “Recharging the batteries”.

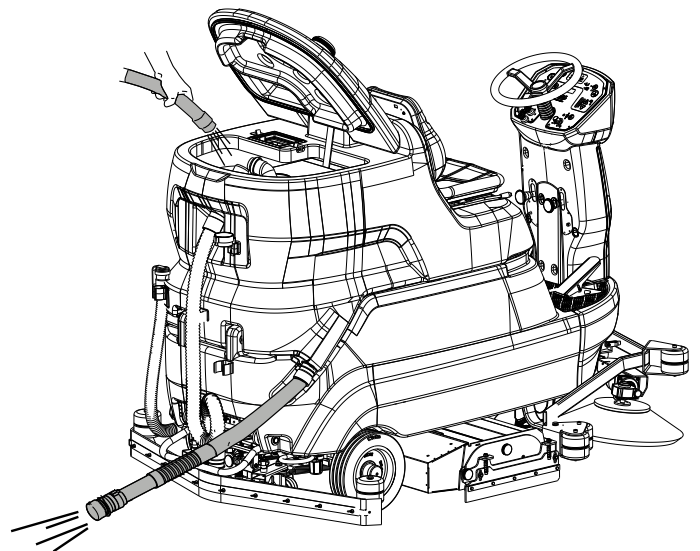

## Emptying the solution tank

**! ATTENTION:** before carrying out the operations described below, stop on a flat and level surface, switch off the machine, remove the ignition key and apply the parking brake.

The detergent solution tank can be emptied by proceeding as follows:

- Take the machine to the designated service area.
- Unhook the hose from the clip.
- Empty the tank by way of the drain hose: keep the hose raised initially and remove the plug, then lower the hose gently and position it over the drain outlet.

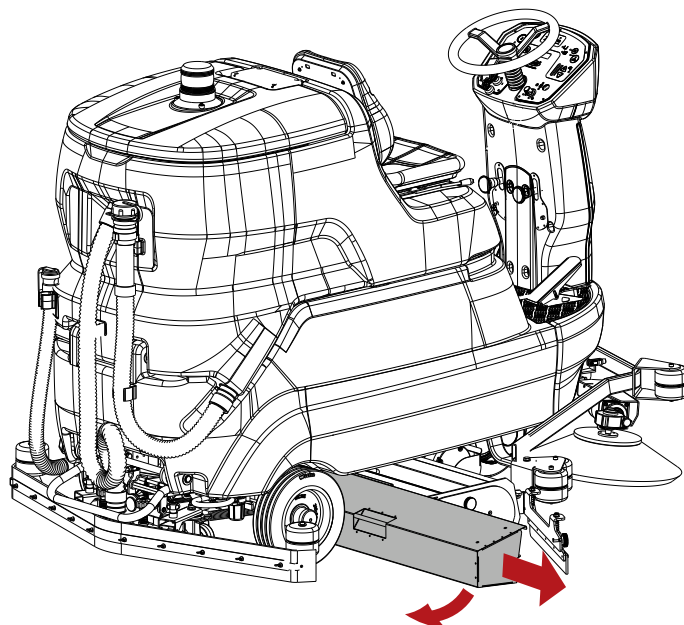

## Removing the the brush/pad drivers

**! ATTENTION:** before carrying out the operations described below, stop on a flat and level surface and apply the parking brake.

- Turn the ignition key to switch the machine on.

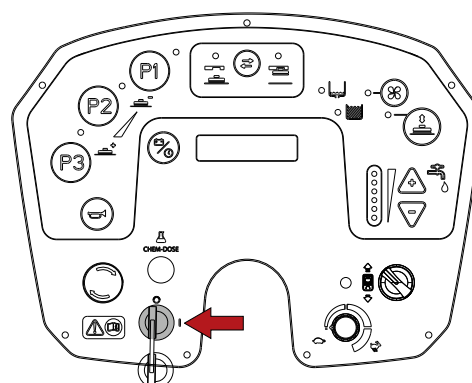
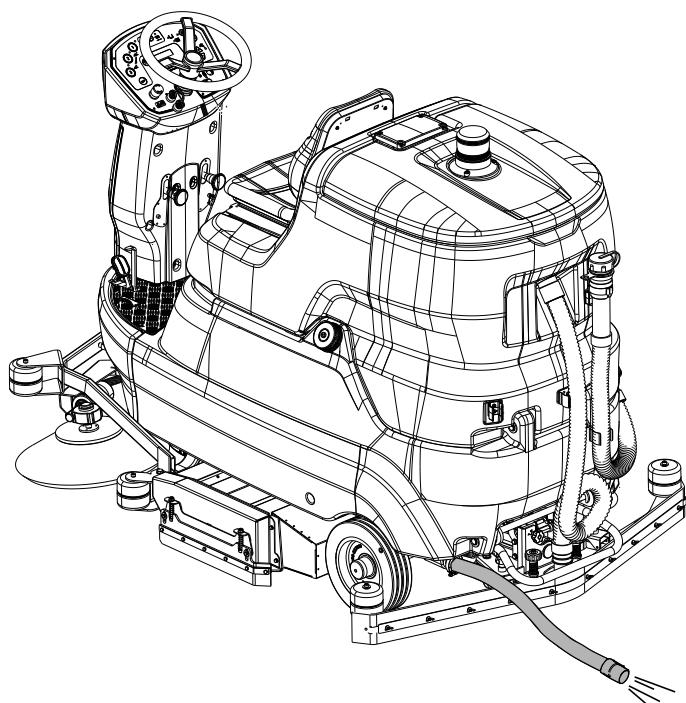

- Press the brush attach/release button; the machine will respond by operating the release mechanism.

## Emptying the debris bin (roller head model)

**! ATTENTION:** before carrying out the operations described below, stop on a flat and level surface, switch off the machine, remove the ignition key and apply the parking brake.

To empty the debris bin on the roller head model, open the right hand side flap by unscrewing the knob, rotate the bottom of the bin clockwise, then pull bin directly out of the machine. Empty the debris and wash the bin.



- Raise the flaps on both side of the machine and remove the brushes from under the head.

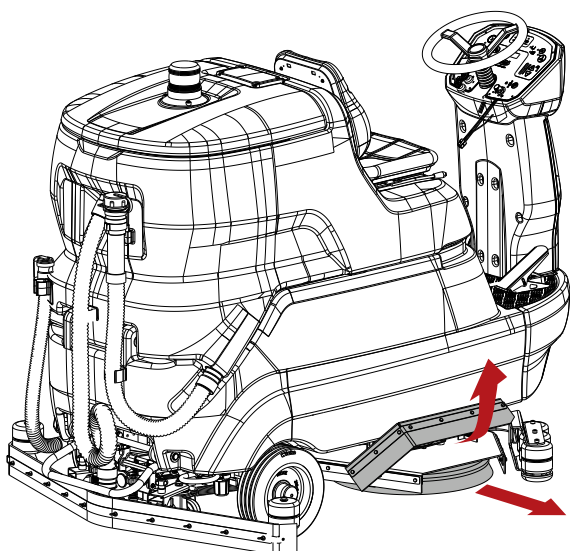

### Moving the machine when not in operation

To move the machine, proceed as follows:

- Turn the ignition key to switch the machine on.
- Press the accelerator pedal.
- The top speed of the machine is adjusted by turning the potentiometer.
- To stop the machine, release the accelerator pedal and depress the brake pedal; refer to the section "**Service brake and parking brake**".
- Turn the ignition key to switch off the machine.
- Apply the parking brake: see section "**Service brake and parking brake**".

# **MAINTENANCE INSTRUCTIONS**

**! DANGER:** no maintenance work of any description must be carried out without first having isolated the machine from its power source. Maintenance operations on the electrical circuit — and in any event, all other operations not explicitly described in this operating manual — must be performed by a **IP CLEANING** approved service technician, in compliance with current safety regulations and as indicated in the maintenance manual.

**! DANGER:** before lifting/turning the dirty water tank in order to access the housing, it must be emptied of its contents.

## **Maintenance - General rules**

Performing regular maintenance according to the Manufacturer's instructions will improve performance and extend the working life of the machine.

When cleaning the machine, always observe the following precautions:

Avoid using pressure washers. Water could penetrate the electrical compartment or motors leading to damage or short circuits;

Avoid using steam, as the heat could cause the deformation of plastic parts;

Do not use solvents or hydrocarbon based products. These can damage the cowling and rubber components.

## **Cleaning the vacuum motor air filter**

**! ATTENTION:** before carrying out the operations described below, stop on a flat and level surface, switch off the machine, remove the ignition key and apply the parking brake.

- Remove the lid of the dirty water tank.

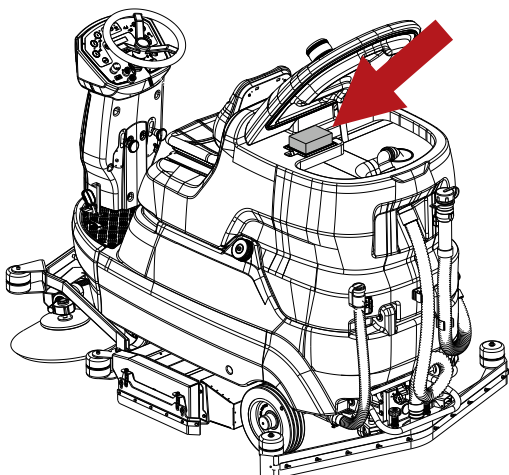

- Release the bezel retaining the filter, by pressing the two tabs inwards.

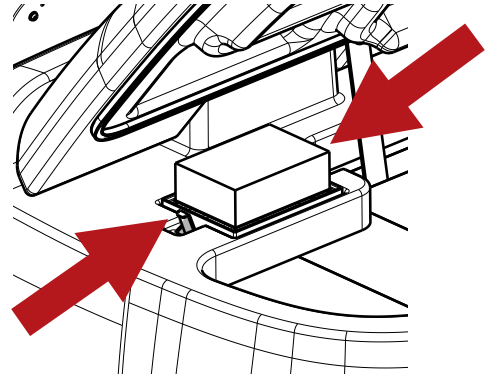

- Detach the bezel.

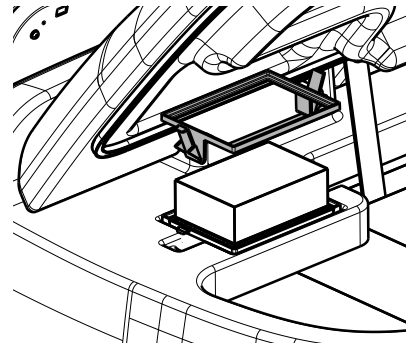

- Remove the filter from its housing.
- Proceed to clean the filter with a damp cloth, or if appreciably soiled, using a low pressure water jet, then make sure the filter is thoroughly dry before reinstalling it.

## **Cleaning the dirty water tank sensor**

**! ATTENTION:** before carrying out the operations described below, stop on a flat and level surface, switch off the machine, remove the ignition key and apply the parking brake.

Raise the lid of the dirty water tank, and clean the sensor as appropriate.

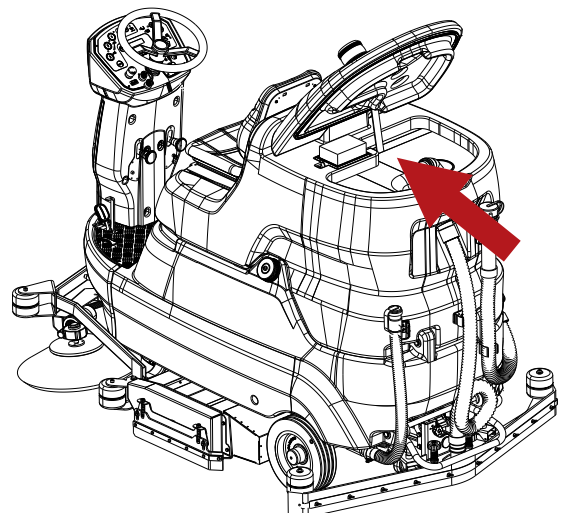

## Cleaning the debris container

**! ATTENTION:** before carrying out the operations described below, stop on a flat and level surface, switch off the machine, remove the ignition key and apply the parking brake.

- Tilt up the lid of the dirty water tank.
- Turn the drain hose to one side.
- Take out the container and clean.

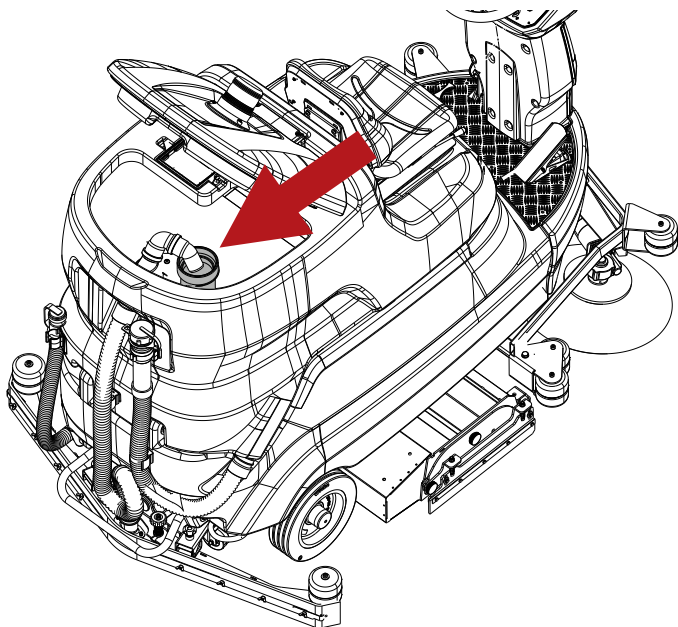

- Unscrew the filter cap, remove the filter, then wash under running water or using the same detergent dispensed by the machine.

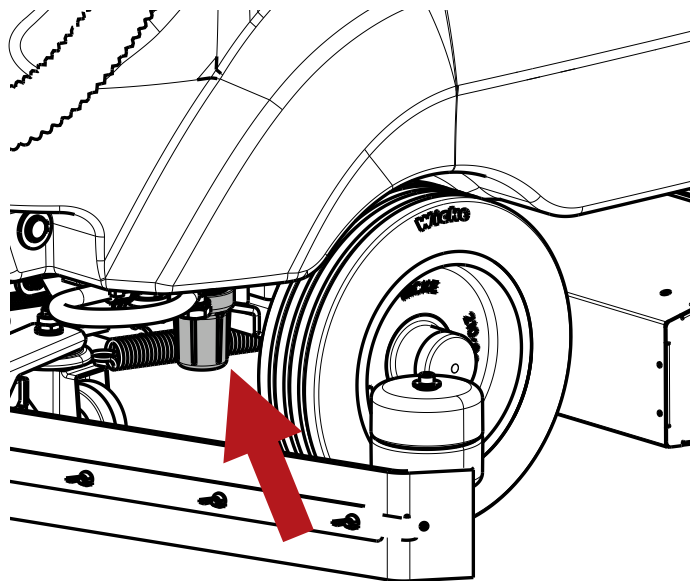

- Replace the filter in its housing, making sure it is correctly positioned and screw the lid back on.

## Cleaning the Chem Dose tank filter (Chem Dose model).

**! ATTENTION:** before carrying out the operations described below, stop on a flat and level surface, switch off the machine, remove the ignition key and apply the parking brake.

To clean the filter, proceed as follows:

- Shut off the tap upstream of the filter.

## Cleaning the solution tank filter

**! ATTENTION:** before carrying out the operations described below, stop on a flat and level surface, switch off the machine, remove the ignition key and apply the parking brake.

To clean the filter, proceed as follows:

- Shut off the tap upstream of the filter.

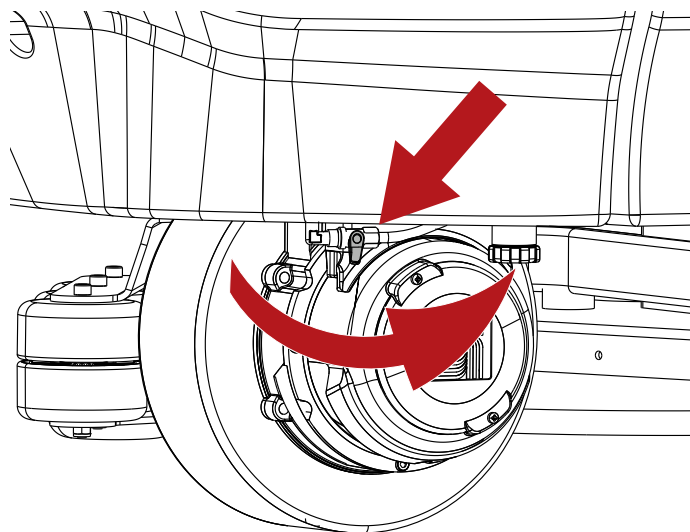

- Unscrew the filter cap, remove the filter, then wash under running water or using the same detergent dispensed by the machine.

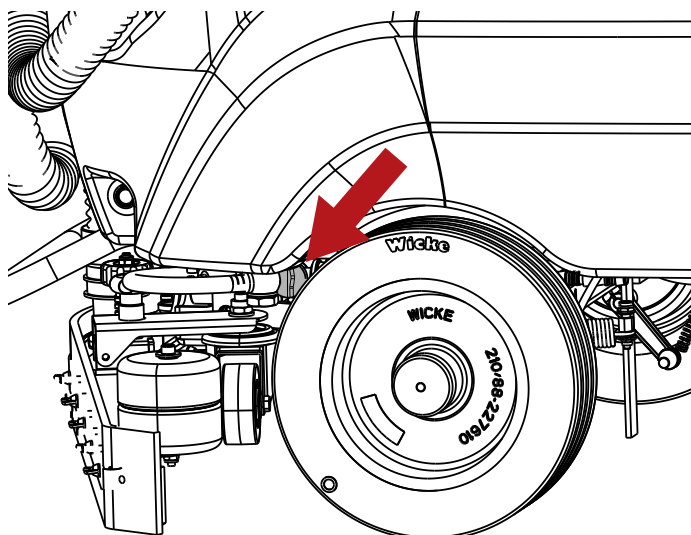



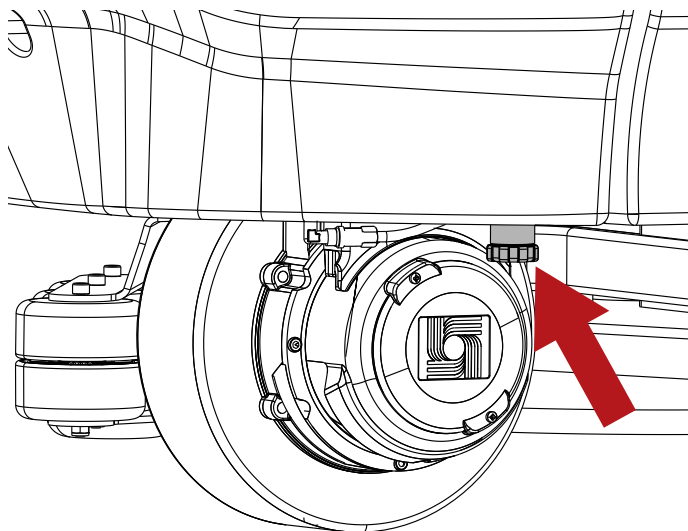

- Replace the filter in its housing, making sure it is correctly positioned and screw the lid back on.

### Fuses:

**! ATTENTION:** before carrying out the operations described below, stop on a flat and level surface, switch off the machine, remove the ignition key and apply the parking brake.

**! ATTENTION:** never install a fuse with a current rating higher than that specified.

The replacement of fuses must be entrusted only to a IP CLEANING service centre or to a IP CLEANING-approved service technician.

Tilt the operator seat toward the steering wheel to access the fuses.

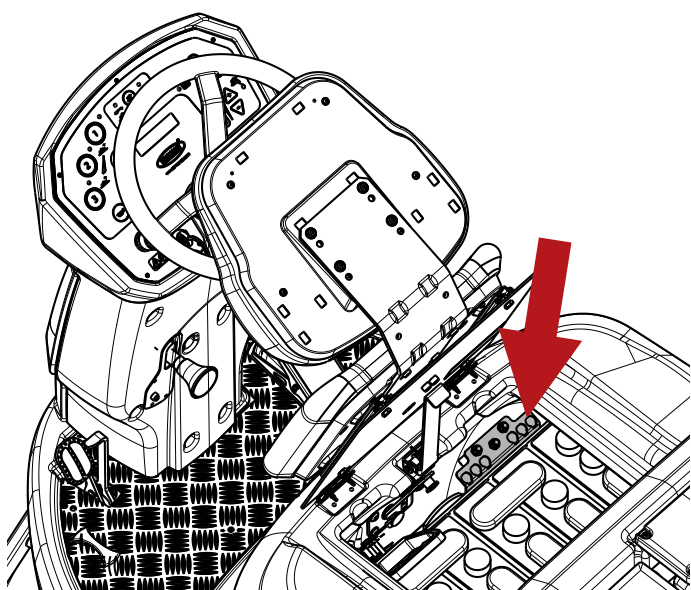

The machine is equipped with resettable fuses also known as thermal fuses. These are resettable devices serving to protect the electrical circuits, which shut off the flow of current in the event of an overload. Once the thermal fuse has been tripped, allow time for it to cool, then press the reset button to restore normal operation.

If the cause of the overload by which the fuse was tripped is still present, the breaker will continue to shut off the flow of current until the issue has been resolved.

### Disk Model

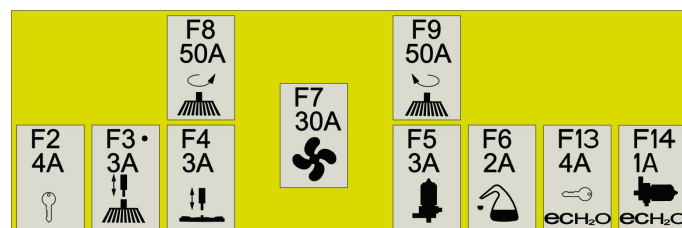

|     |                              |
|-----|------------------------------|
| F2  | Fuse Key                     |
| F3  | Fuse Brush Actuator          |
| F4  | Fuse Squeegee Actuator       |
| F5  | Fuse Water Pump              |
| F6  | Fuse Chem Dose Pump          |
| F7  | Fuse Vacuum                  |
| F8  | Fuse Right Brush Motor       |
| F9  | Fuse Left Brush Motor        |
| F13 | Fuse Device ec-H2O NanoClean |
| F14 | Fuse ec-H2O NanoClean Pump   |

### Roller Head Model

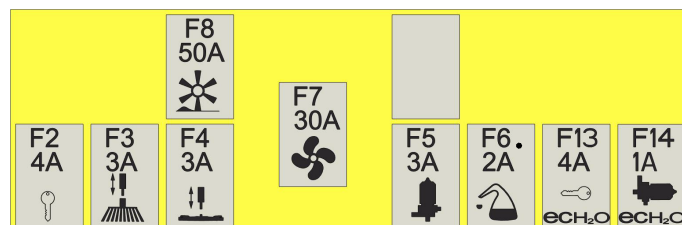

|     |                              |
|-----|------------------------------|
| F2  | Fuse Key                     |
| F3  | Fuse Brush Actuator          |
| F4  | Fuse Squeegee Actuator       |
| F5  | Fuse Water Pump              |
| F6  | Fuse Chem Dose Pump          |
| F7  | Fuse Vacuum                  |
| F8  | Fuse Brush Motor             |
| F13 | Fuse Device ec-H2O NanoClean |
| F14 | Fuse ec-H2O NanoClean Pump   |

## ! NOTICE

A resettable fuse is fitted beneath each of the side brush operating levers.

In the event that a side brush should stop working, press the button to reset the fuse.

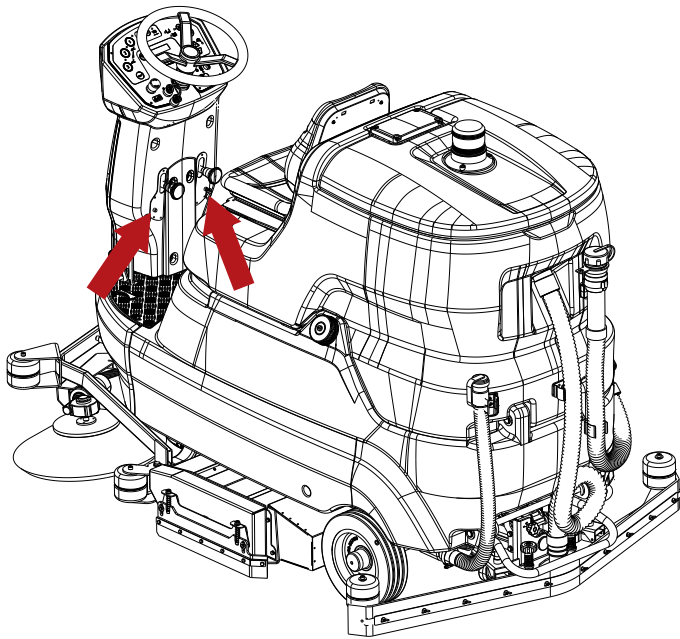

## Battery maintenance

**! DANGER:** do not check the batteries by sparking. Lead-acid (WET) batteries give off flammable vapours: extinguish any naked flames or embers before checking or topping up the batteries.

**! DANGER:** during any type of maintenance on the batteries, the operator technician must wear the Personal Protective Equipment (gloves, eyewear, overalls, etc.) needed to limit the risk of accidents. Keep away from naked flames, do not short circuit the battery poles, do not generate sparks and do not smoke.

**! DANGER:** in the event of battery fluid leakage, do not touch the fluid and observe the following precautions:  
Contact with the skin can cause irritation; wash with soap and water.  
Inhalation of vapours can cause irritation to the airways; stay out in the open air and consult a doctor.  
Contact with eyes can cause irritation, wash eyes immediately and thoroughly with water for at least 15 minutes; consult a doctor.

Useful battery life is dependent on proper maintenance. To obtain best possible efficiency from batteries, observe the following rules:

- Do not leave batteries partially discharged for long periods of time.
- Allow batteries to charge completely before resuming use of the machine.
- Keep batteries clean, with the connections always well tightened.
- Check the level of the electrolyte every week (WET batteries).

## Checking the electrolyte level of WET batteries

**! ATTENTION:** before carrying out the operations described below, stop on a flat and level surface, switch off the machine, remove the ignition key and apply the parking brake.

**! DANGER:** during any type of maintenance on the batteries, the operator technician must wear the Personal Protective Equipment (gloves, eyewear, overalls, etc.) needed to limit the risk of accidents. Keep away from naked flames, do not short circuit the battery poles, do not generate sparks and do not smoke.

WET batteries must be inspected periodically to check the level of the electrolyte. Use only distilled water to top up the level so that the plates are covered. Do not overfill (maximum 5 mm above the plates), as the electrolyte could expand and overflow when the battery is charged.

## Automatic top-up system for 320Ah WET battery.

**! ATTENTION:** before carrying out the operations described below, stop on a flat and level surface, switch off the machine, remove the ignition key and apply the parking brake.

**! DANGER:** during any type of maintenance on the batteries, the operator technician must wear the Personal Protective Equipment (gloves, eyewear, overalls, etc.) needed to limit the risk of accidents. Keep away from naked flames, do not short circuit the battery poles, do not generate sparks and do not smoke.

**! WARNING:** the electrolyte must be topped up after the batteries have been recharged.

## ! NOTICE

Check the level of the battery electrolyte, which can be detected from the floats (indicated by the white dot) of the automatic top-up system.

If the levels of the floats (indicated by the white dot) are low, proceed to top up the electrolyte using distilled water only:

- Position the container of distilled water at a height at least one metre above the top rim of the battery.
- Connect the battery filler tube to the hose of the container, removing the dust plug.
- Unscrew the cap of the container enough to allow the inflow of air.
- Open the tap of the container.
- Wait for completion of the top-up, which is confirmed when the flow indicator stops turning.
- Close the tap of the container.
- Disconnect the battery filler tube from the hose of the container, replacing the dust plug.
- Check the levels of the floats (indicated by the white dot) to ensure that all are raised.

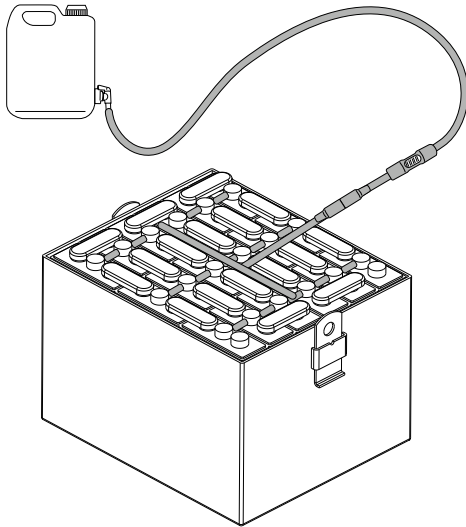

**! DANGER:** when charging the batteries, highly explosive hydrogen gas is produced. Keep the operator seat tilted toward the steering wheel throughout the battery charging cycle and carry out this procedure only in well-ventilated areas, away from naked flames.

**! ATTENTION:** before carrying out the operations described below, stop on a flat and level surface, switch off the machine, remove the ignition key and apply the parking brake.

**! ATTENTION:** before recharging, make certain that the battery charger is set up correctly for the type of battery installed.

**! ATTENTION:** run the recharge cycle exactly as specified in the battery charger manual, and at the end of the cycle, detach the connectors.

- Disconnect the battery pack connector from the electrical system of the machine.
- Connect the battery pack connector to the connector of the battery charger.
- Plug the battery charger into the mains power socket.
- Start the recharge cycle.

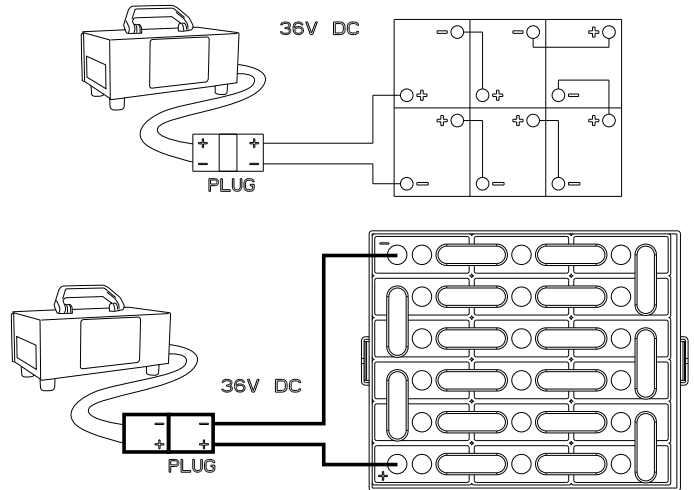

## Recharging the batteries



**! DANGER:** do not check the batteries by sparking. Lead-acid (WET) batteries give off flammable vapours: extinguish any naked flames or embers before checking or topping up the batteries.



**! DANGER:** carry out the operations described below in a ventilated area.

## Battery: removal

**! DANGER:** in the event of battery fluid leakage, do not touch the fluid and observe the following precautions:  
Contact with the skin can cause irritation; wash with soap and water.  
Inhalation of vapours can cause irritation to the airways; stay out in the open air and consult a doctor.  
Contact with eyes can cause irritation, wash eyes immediately and thoroughly with water for at least 15 minutes; consult a doctor.

**! DANGER:** When removing the batteries, the skilled technician must wear the Personal Protective Equipment (gloves, eyewear, overalls, etc.) needed to limit the risk of accidents; remove the ignition key from the control panel before proceeding with the removal operation, keep away from naked flames, do not short circuit the battery poles, do not cause sparks and do not smoke.

**! ATTENTION:** before carrying out the operations described below, stop on a flat and level surface, switch off the machine, remove the ignition key and apply the parking brake.

- Disconnect the terminals of the battery cables from the battery poles.
- If necessary, remove the devices fixing the battery to the base of the machine.
- Lift the batteries from the compartment using suitable handling equipment.

## Replacement of Brushes and Pads

**! DANGER:** during installation, the operator must wear personal protective equipment (gloves, eyewear, overalls, etc.) needed to limit the risk of accidents.

The machine can be equipped with disc brushes, roller brushes and pads. Check the brushes and the pads every day to make certain there are no wires, threads or strings entangled around the brush or the drive board. Check for wear on the brushes and the pads.

Replace the brushes when the bristles are worn down to the point of exposing the red indicator.

Replace the pads when they no longer clean efficiently.

Wash the brushes and pads with soap and water following use, and hang them up to dry.

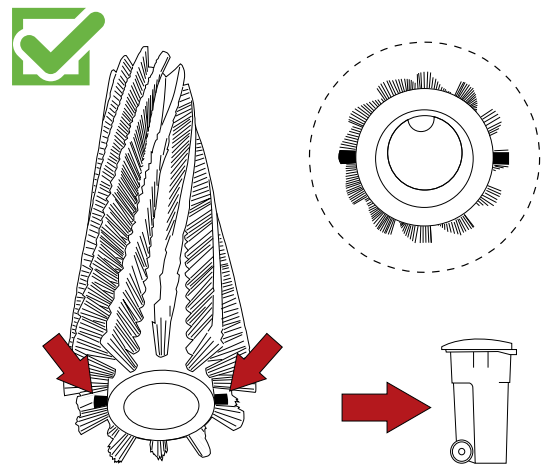
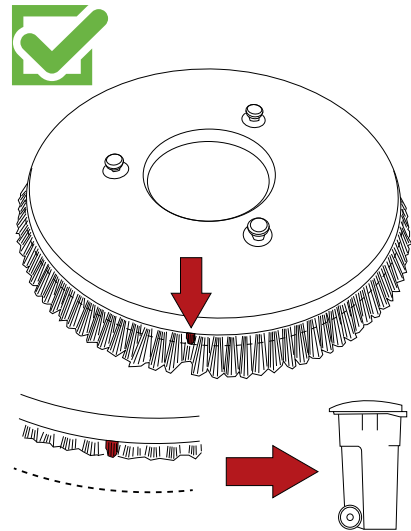

## Replacing the squeegee blades

**! ATTENTION:** before carrying out the operations described below, stop on a flat and level surface, switch off the machine, remove the ignition key and apply the parking brake.

**! DANGER:** during installation, the operator must wear personal protective equipment (gloves, eyewear, overalls, etc.) needed to limit the risk of accidents.

The squeegee blades collect the film of water and detergent from the floor and prepare the way for perfect drying. With time, and the constant wiping action, the edge of the blade in contact with the floor becomes rounded and cracked, diminishing its drying efficiency, so that ultimately a new blade is required.

- Remove the vacuum hose from the squeegee.
- Remove the squeegee from its mount by unscrewing the two knobs completely.

- Unscrew the nuts.
- Remove the blade retainers.
- Remove the blade.
- Refit the same rear blade, switching it around so that all four edges in turn are placed in contact with the floor, until all are worn out, proceeding likewise for the front blade, in this case until the two edges are worn out; alternatively, replace with a new blade, fitting it to the screws on the body of the squeegee.
- Refit the blade retainers.
- Tighten the nuts.
- Replace the squeegee on its mount.

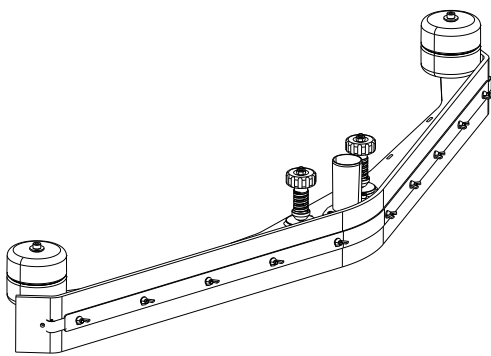
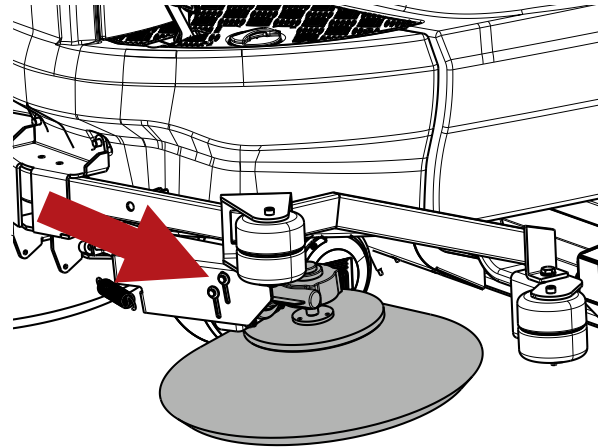

### Side brushes wear adjustment(roller head model).

**! ATTENTION:** before carrying out the operations described below, stop on a flat and level surface, switch off the machine, remove the ignition key and apply the parking brake.

**! DANGER:** during installation, the operator must wear personal protective equipment (gloves, eyewear, overalls, etc.) needed to limit the risk of accidents.

If the side brushes (when lowered) do not touch the floor due to excessive wear, they can be adjusted as follows:

- Move the side brush to the working position.
- Loosen the adjustment screws on the brush motor support.
- Position the brush by hand, as required.
- Tighten the adjustment screws.

### Machine Jacking

**! ATTENTION:** before carrying out the operations described below, stop on a flat and level surface, switch off the machine, remove the ignition key and apply the parking brake.

- ! DANGER:** when lifting the machine, use suitable equipment with a load capacity sufficient to carry its weight.
- ! DANGER:** the machine must be lifted only from the points indicated below.
- ! DANGER:** empty the dirty water and detergent solution tanks before lifting the machine.
- ! DANGER:** remove the batteries before lifting the machine.

**! NOTICE**  
Front and rear lifting points are provided on both sides of the machine.

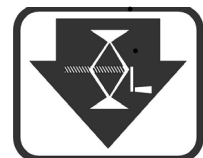
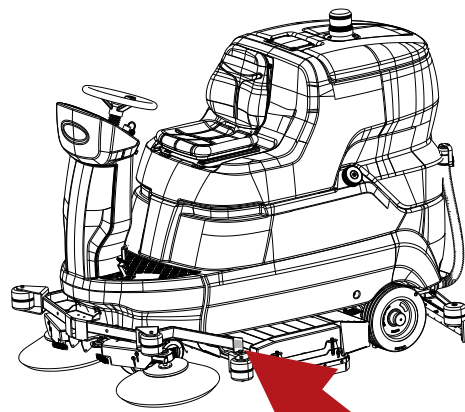

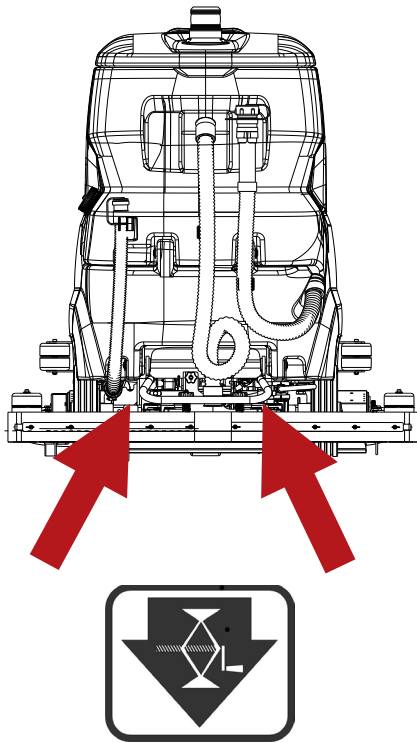

|   |  |   |   |
|---|--|---|---|
| CHECK THE BATTERY ELECTROLYTE LEVEL   |  | X |   |
| HAVE THE ELECTRICAL SYSTEM CHECKED BY A IP CLEANING-APPROVED SERVICE TECHNICIAN |  |   | X |
| CLEAN AND CHECK SCRUB BRUSHES FOR WEAR  | X  |   |   |
| REPLACE CARBON BRUSHES  | VACUUM MOTOR (750 hours)<br>PROPEL AND BRUSH MOTORS (1250 hours) |   |   |

## PERIODS OF INACTIVITY

If the machine is not used for some time, for example, on display in a showroom or stored in the warehouse for a period of more than one month, the following operations are required:

- Recharge the batteries completely. During long periods of inactivity, remember to recharge the batteries periodically (at least once every two months) so that they are kept at the maximum charge level.
- Disconnect the batteries from the machine.
- Unplug the battery charger (if present) from the mains power supply.
- The squeegee and brushes (or abrasive disks) must be removed from the machine, washed and stored in a dry place (preferably in a bag or wrapped in plastic sheet) away from dust.
- Make certain that the tanks are completely empty and perfectly clean.

**! ATTENTION:** remember to check the batteries — if they are not recharged periodically as described above, they could become damaged beyond repair. The manufacturer is not liable for any malfunctions resulting from neglect, improper and/or incorrect use.

**! ATTENTION:** when the batteries discharge to the minimum level, make certain they are not left in this condition for any length of time, as this can reduce their working life. Check the battery charge level at least once a week

### Periodic checks

| CHECK   | DAILY OPERATIONS | WEEKLY OPERATIONS | SIX MONTHLY OPERATIONS |
|---|------------------|-------------------|------------------------|
| EMPTY AND WASH THE DIRTY WATER TANK                       | X                |                   |                        |
| CLEAN THE SQUEEGEE BLADES AND CHECK THEM FOR WEAR         | X                |                   |                        |
| CHECK THAT THE VACUUM HOLE IN THE SQUEEGEE IS NOT BLOCKED | X                |                   |                        |
| RECHARGE THE BATTERIES                                    | X                |                   |                        |
| CLEAN THE DIRTY WATER TANK FLOAT                          |                  | X                 |                        |
| CLEAN THE VACUUM MOTOR AIR FILTER                         |                  | X                 |                        |
| CLEAN THE SOLUTION TANK FILTER                            |                  | X                 |                        |
| CLEANING THE CHEM DOSE TANK FILTER (CHEM DOSE MODEL).     |                  | X                 |                        |
| CLEAN THE SQUEEGEE  |                  | X                 |                        |
| CLEAN THE DIRTY WATER TANK AND THE SOLUTION TANK          |                  | X                 |                        |

# TROUBLESHOOTING

| PROBLEMS  | CAUSES   | SOLUTIONS   |
|---|--|---|
| Machine not working                                       | The batteries are disconnected   | Connect the batteries to the machine  |
|   | The batteries are flat   | Recharge the batteries  |
|   | Fuse tripped   | Reset the fuse  |
|   | Ignition key not engaged   | Turn the key  |
|   | Emergency button pressed   | Release the emergency button  |
| Head brushes not turning                                  | The dirty water tank is full   | Empty the dirty water tank  |
|   | Motor fuse tripped   | Reset the fuse  |
|   | The batteries are flat   | Recharge the batteries  |
|   | Damaged motor  | Contact Customer Service  |
| Head assembly not lowering/working                        | The batteries are flat   | Recharge the batteries  |
|   | The dirty water tank is full   | Empty the dirty water tank  |
|   | Actuator fuse tripped  | Reset the fuse  |
|   | Actuator damaged   | Contact Customer Service  |
| Side brushes not turning (roller head model)              | Brushes raised   | Lower the side brushes  |
|   | Motor fuse tripped   | Reset the fuse  |
|   | Damaged motor  | Contact Customer Service  |
| The machine does not clean uniformly                      | The brush or disks are worn  | Replace   |
| No liquid flowing from the solution tank                  | Damaged solenoid valve   | Contact Customer Service  |
|   | Dirty solenoid valve   | Contact Customer Service  |
|   | Detergent tank filter dirty  | Clean the filter  |
|   | Detergent solution tank empty  | Top up  |
|   | The hose delivering detergent to the brush is blocked                              | Unblock   |
|   | The tap upstream of the filter is closed   | Open the tap  |
|   | Pump fuse tripped  | Reset the fuse  |
|   | Pump damaged   | Contact Customer Service  |
| Detergent flow does not stop                              | Damaged solenoid valve   | Contact Customer Service  |
|   | Dirty solenoid valve   | Contact Customer Service  |
| Vacuum motor not working                                  | The dirty water tank is full   | Empty the dirty water tank  |
|   | Vacuum motor fuse tripped  | Reset the fuse  |
|   | The batteries are flat   | Recharge the batteries  |
|   | Damaged motor  | Contact Customer Service  |
| Squeegee not wiping properly or not vacuuming efficiently | The edge of the rubber blades in contact with the floor is worn                    | Replace the blades  |
|   | Squeegee blocked or damaged  | Check   |
|   | The dirty water tank sensor has been activated or is blocked by dirt, or is faulty | Empty the dirty water tank, check the sensor.   |
|   | Blockage in the vacuum hose  | Check   |
|   | The vacuum hose is not connected to the squeegee or is damaged                     | Check   |
|   | Actuator fuse tripped  | Reset the fuse  |
|   | Actuator damaged   | Contact Customer Service  |
| The machine does not move                                 | The batteries are flat   | Recharge the batteries  |
|   | Damaged motor  | Contact Customer Service  |
|   | Accelerator pedal pressed too quickly  | When starting, press the accelerator pedal slowly   |
| The batteries do not provide the normal working time      | The battery poles and charging terminals are dirty and oxidised                    | Clean and grease the poles and terminals, charge the batteries                                      |
|   | The electrolyte has evaporated and is not covering the plates completely           | Top up all elements with distilled water so that all plates are covered, then recharge the battery. |
|   | The battery charger does not work or is not suitable                               | Check   |

Models with Chem Dose  
Detergent not flowing from tank

|  |                          |
|--|--------------------------|
| Chem Dose tank empty                           | Top up                   |
| Chem Dose tank filter dirty                    | Clean the filter         |
| Tap upstream of the Chem Dose filter is closed | Open the tap             |
| Pump fuse tripped                              | Reset the fuse           |
| Pump damaged                                   | Contact Customer Service |



## ALARMS/WARNINGS DISPLAYED

| ERROR CODE        | CAUSE   | SOLUTION  |
|-------------------|---|---|
| BRUSH TEMPERATURE | Machine being overworked.                                       | Wait 30 minutes for the temperature to come down.     |
|                   | The work program selected is too heavy for the type of surface. | Drop from 3 to 2 or 1.                                |
|                   | Electronics damaged   | Replace the power pcb.                                |
| BATTERY RESERVE   | Low battery voltage.  | Charge the battery.                                   |
| BATTERY LOW       | Low battery voltage.  | Charge the battery.                                   |
| BATTERY FLAT      | Low battery voltage.  | Check the battery acid level and top up if necessary. |
| PARKING BRAKE     | Parking brake engaged.  | Release the parking brake.                            |
|                   | Brake pedal microswitch not mounted correctly.                  | Adjust the position of the microswitch.               |
|                   | Brake pedal microswitch not functioning correctly.              | Replace the microswitch.                              |
| DIRTY WATER LEVEL | Water level sensor tripped.                                     | Empty the dirty water tank.                           |
|                   | Level sensor stuck.   | Check the sensor.                                     |
| WATER RESERVE     | Water level sensor tripped.                                     | Prepare to empty the dirty water tank.                |
|                   | Level sensor stuck.   | Check the sensor.                                     |
| NO WATER          | Water level sensor tripped.                                     | Fill the solution tank.                               |
|                   | Level sensor stuck.   | Check the sensor.                                     |
| DETERGENT RESERVE | Chemical detergent almost depleted.                             | Fill the Chem-Dose tank.                              |
| NO DETERGENT      | Chemical detergent entirely depleted                            | Fill the Chem-Dose tank.                              |



# USER MENU

To access the user program, turn the ignition key to "1"; after 5 seconds, press the programming button and hold for 10 seconds. The display will show the first parameter. To switch from one parameter to another, use the programming button.

To change the value of the selected parameter, press the "-" or "+" button: "-" to decrease, "+" to increase.

To store the changes and exit, press and hold the programming button until the display shows the battery voltage.

Simply returning the ignition key to "0" will not cancel the changes that have been made; to clear the changes, set the default values shown below and select save.

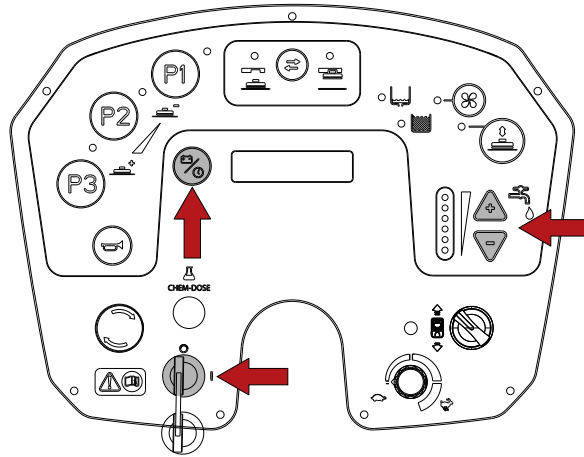

|                       | DEFAULT VALUES                 |                                |
|-----------------------|--------------------------------|--------------------------------|
|                       | Disc Head version              | Roller Head version            |
| Language setting.     | ENGLISH                        | ENGLISH                        |
| Head working pressure | Program 1<br>Pressure 020      | Program 1<br>Pressure 020      |
| Enable brushes        | Program 1<br>Brushes ON        | Program 1<br>Brushes ON        |
| Enable vacuum unit.   | Program 1<br>Vacuum unit ON    | Program 1<br>Vacuum unit ON    |
| Water flow rate.      | Program 1<br>Water 2           | Program 1<br>Water 2           |
| Enable Power OFF- ON. | Program 1<br>Auto Power OFF ON | Program 1<br>Auto Power OFF ON |
| Head working pressure | Program 2<br>Pressure 040      | Program 2<br>Pressure 030      |
| Enable brushes        | Program 2<br>Brushes ON        | Program 2<br>Brushes ON        |
| Enable vacuum unit.   | Program 2<br>Vacuum unit ON    | Program 2<br>Vacuum unit ON    |
| Water flow rate.      | Program 2<br>Water 3           | Program 2<br>Water 3           |
| Enable Power OFF- ON. | Program 2<br>Auto Power OFF ON | Program 2<br>Auto Power OFF ON |
| Head working pressure | Program 3<br>Pressure 060      | Program 3<br>Pressure 040      |
| Enable brushes        | Program 3<br>Brushes ON        | Program 3<br>Brushes ON        |
| Enable vacuum unit.   | Program 3<br>Vacuum unit ON    | Program 3<br>Vacuum unit ON    |
| Water flow rate.      | Program 3<br>AUTO water        | Program 3<br>Water 3           |
| Enable Power OFF- ON. | Program 3<br>Auto Power OFF ON | Program 3<br>Auto Power OFF ON |
| Detergent flow rate.  | Chemical flow rate.<br>2%      | Chemical flow rate.<br>2%      |



**IPC**

BY TENNANT COMPANY

IP Cleaning S.r.l.  
Viale Treviso 63  
30026 Summaga di Portogruaro  
Venezia (Italy)  
T: +39 0421 205511  
F: +39 0421 204227  
E: [www.ipcworldwide.com](http://www.ipcworldwide.com)  
W: [info@ipcworldwide.com](mailto:info@ipcworldwide.com)

