

DIMENSIONI MACCHINA - SIZE OF MACHINE
 MASCHINENABMESSUNGEN - DIMENSIONES DE LA MÁQUINA
 DIMENSIONS MACHINE - AFMETINGEN MACHINE
 DIMENSÕES DA MÁQUINA - MASKINENS DIMENSIONER
 MASKINENS DIMENSJONER - РАЗМЕРЫ МАШИНЫ
 РАЗМЕР НА МАШИНАТА

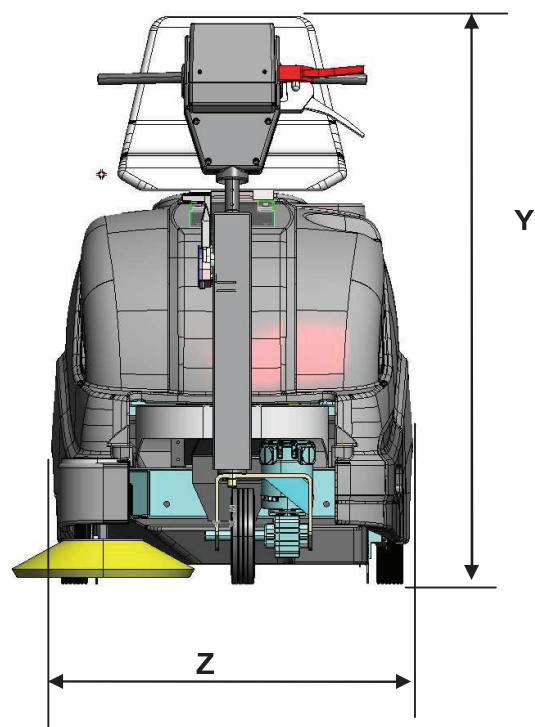

- X-Y-Z: Vedi tabella "CARATTERISTICHE TECNICHE"
 X-Y-Z: See "TECHNICAL CHARACTERISTICS"
 X-Y-Z: Siehe Tabelle "TECHNISCHE EIGENSCHAFTEN"
 X-Y-Z: Véase la tabla "CARACTERÍSTICAS TÉCNICAS"
 X-Y-Z: Voir tableau "CARACTERISTIQUES TECHNIQUES"
 X-Y-Z: Zie tabel "TECHNISCHE EIGENSCHAPPEN"
 X-Y-Z: Ver a tabela "CARACTERÍSTICAS TÉCNICAS"
 X-Y-Z: Se tabellen "TEKNISKA SPECIFIKATIONER"
 X-Y-Z: Se tabellen "TEKNISKE EGENSKAPER"
 X-Y-Z: См. таблицу "ТЕХНИЧЕСКИЕ ХАРАКТЕРИСТИКИ"
 X-Y-Z: Вж. таблица "ТЕХНИЧЕСКИ ХАРАКТЕРИСТИКИ"

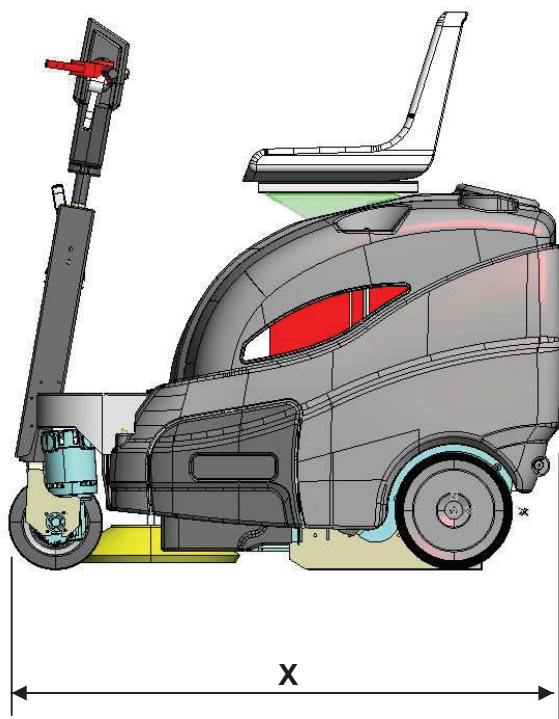
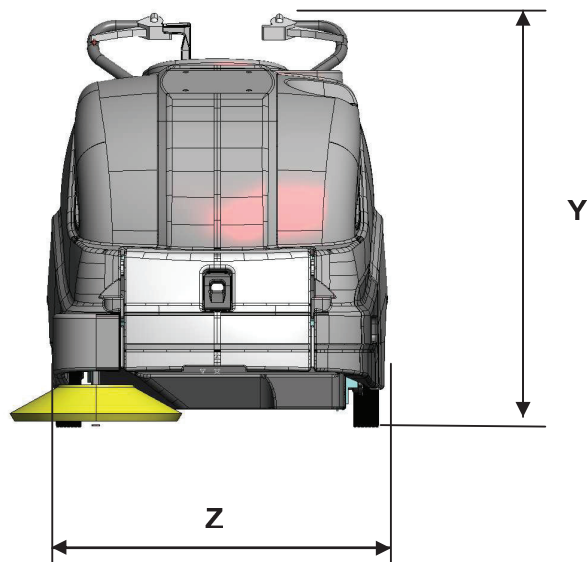
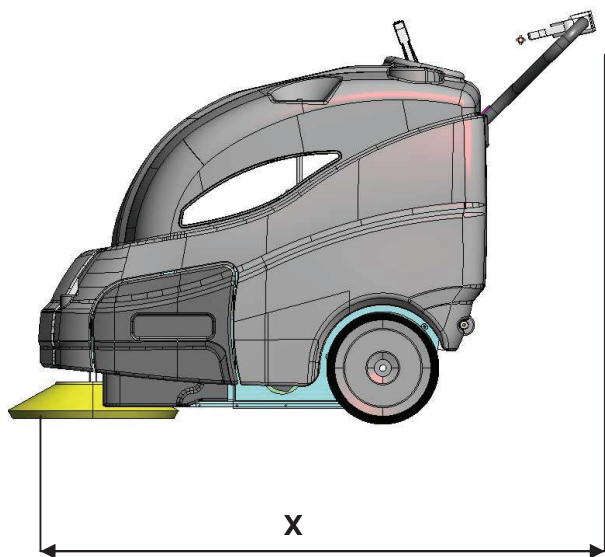
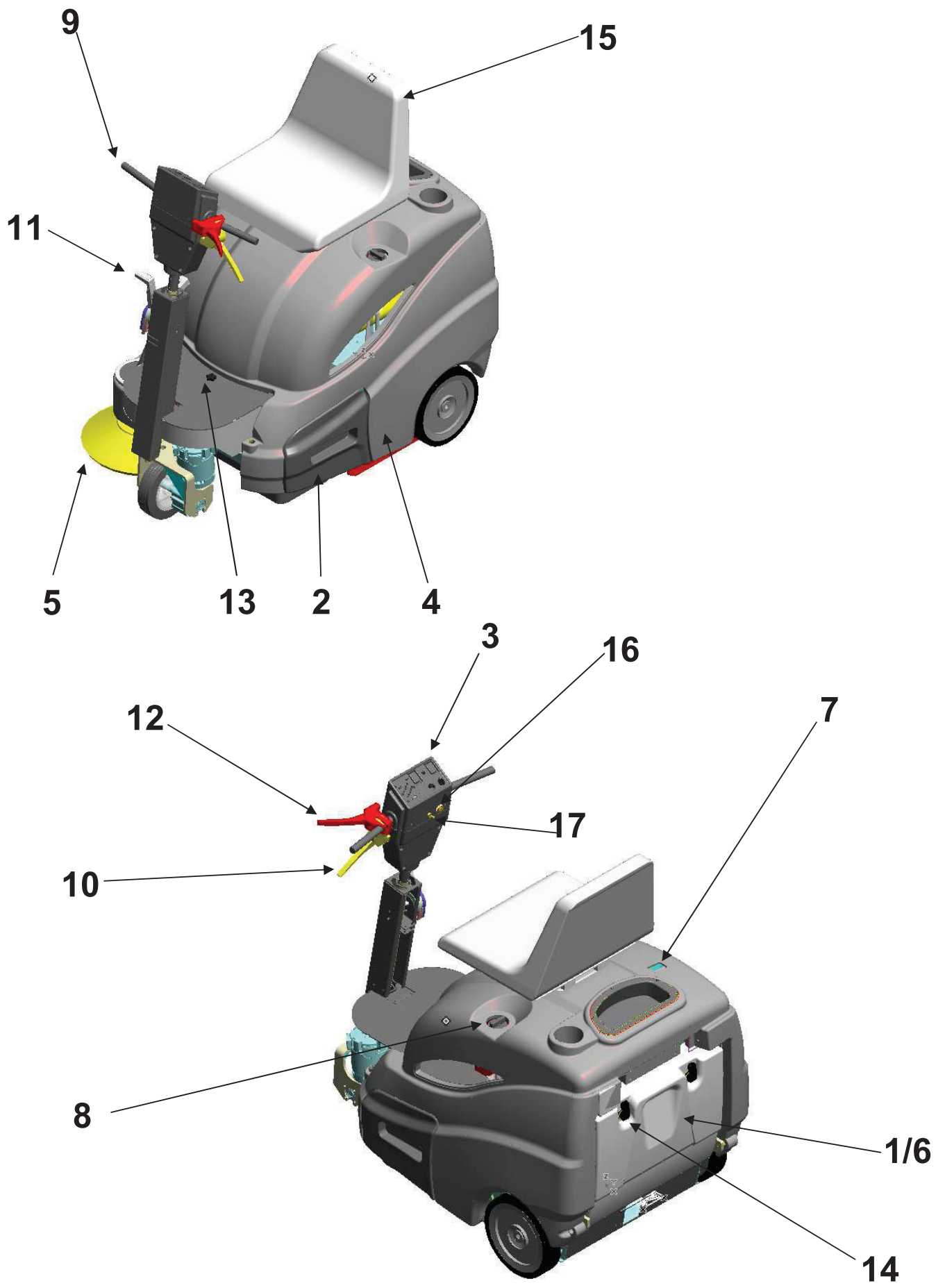

A

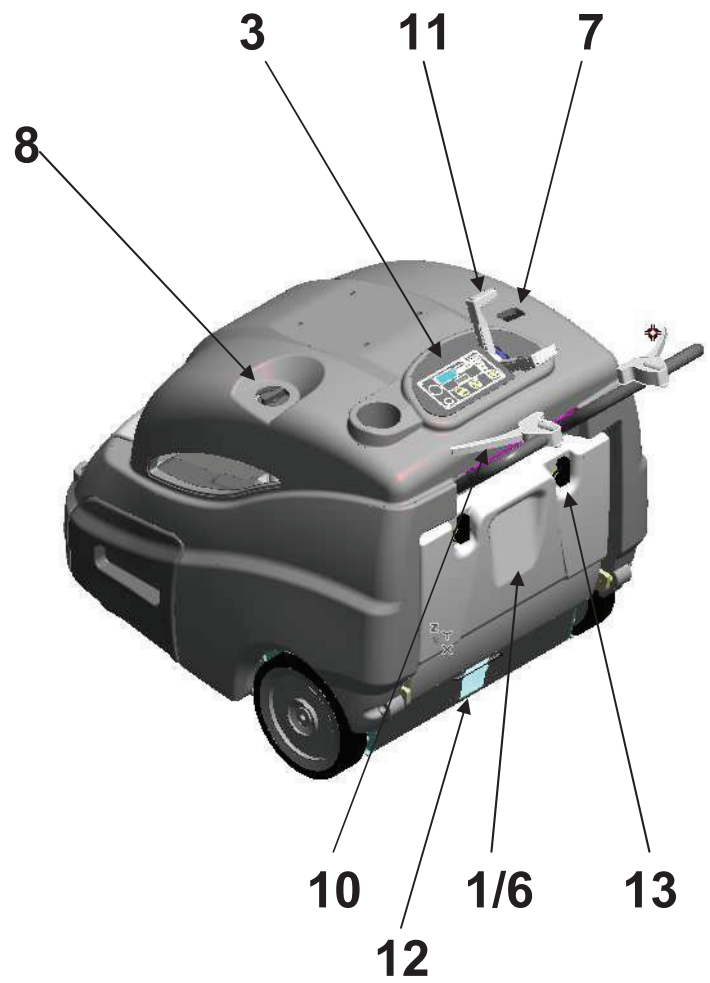

B

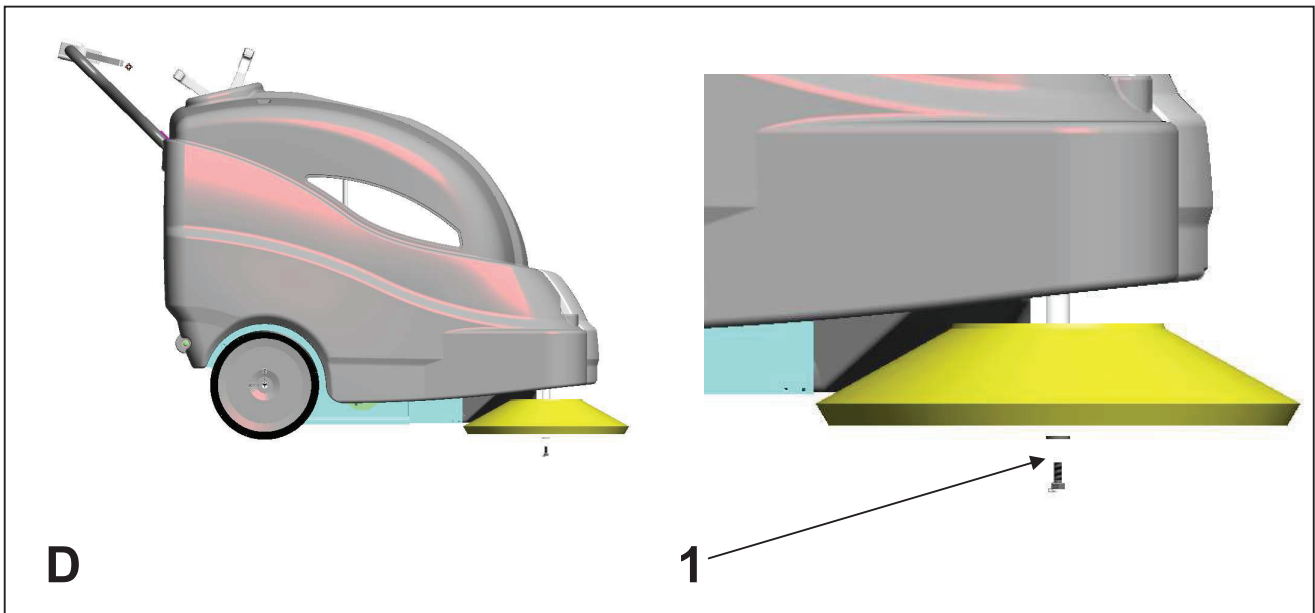
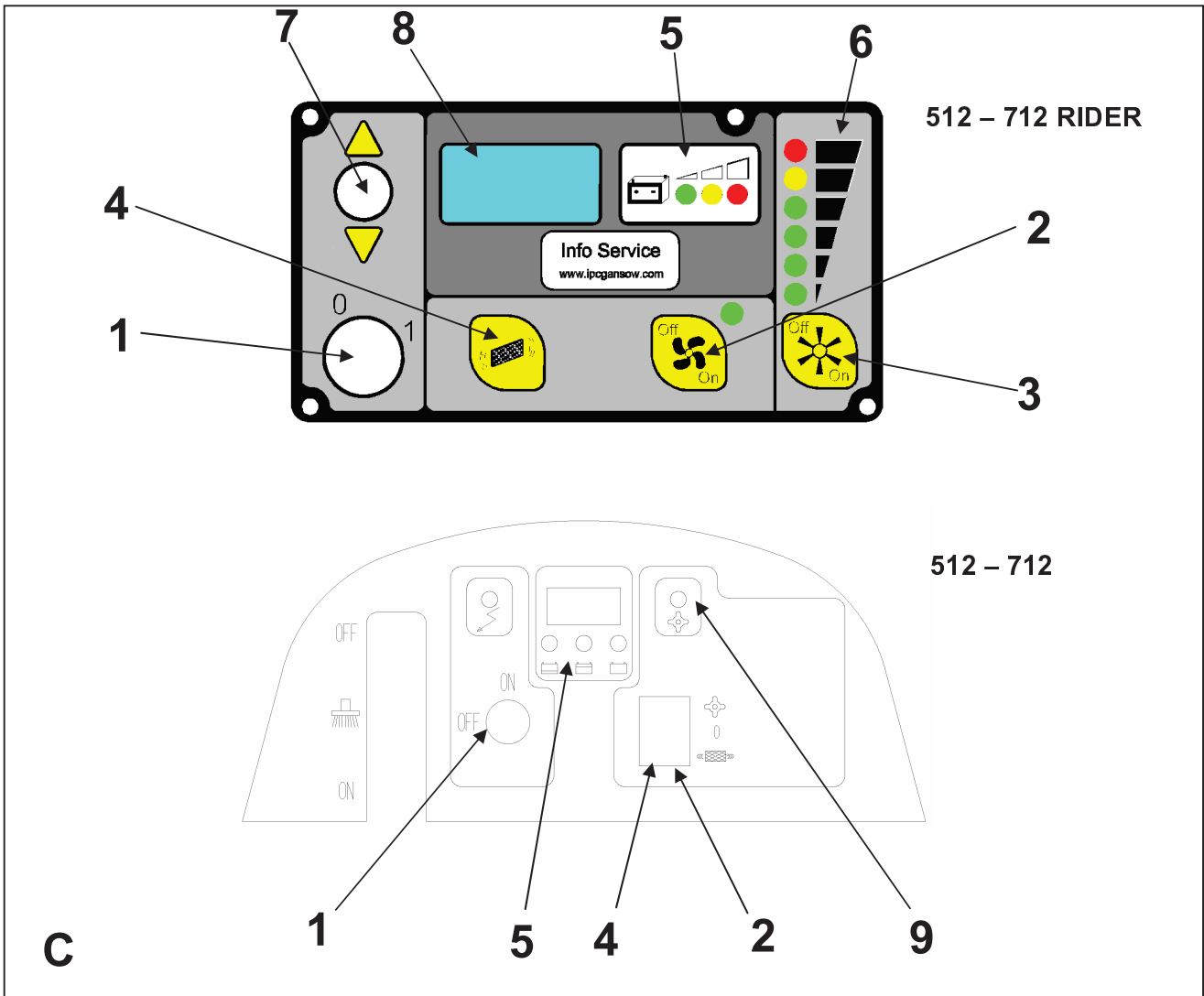

E

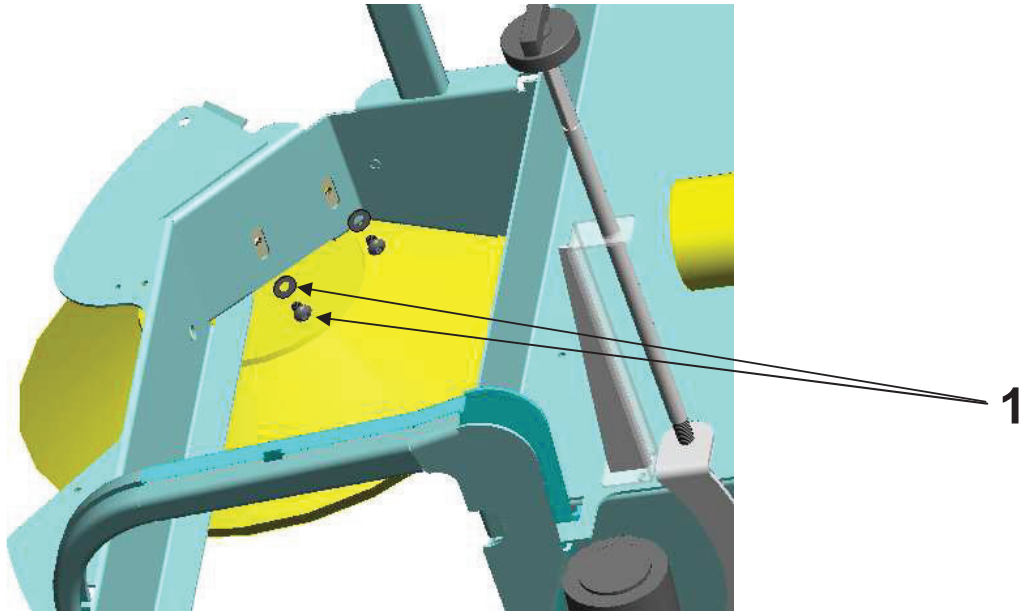

F

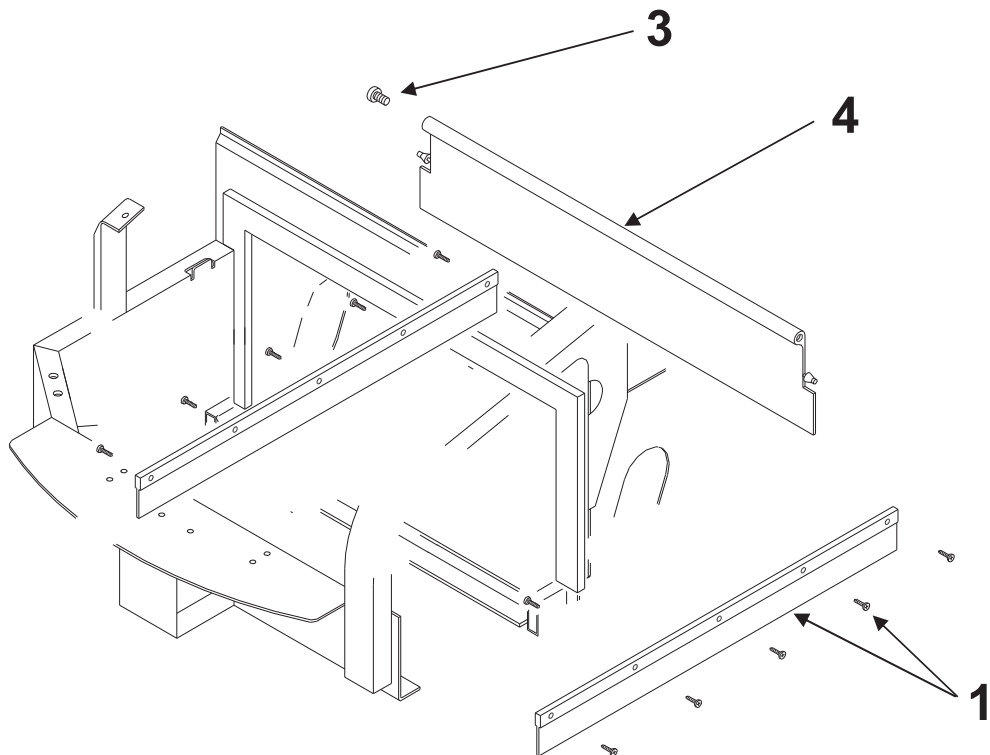

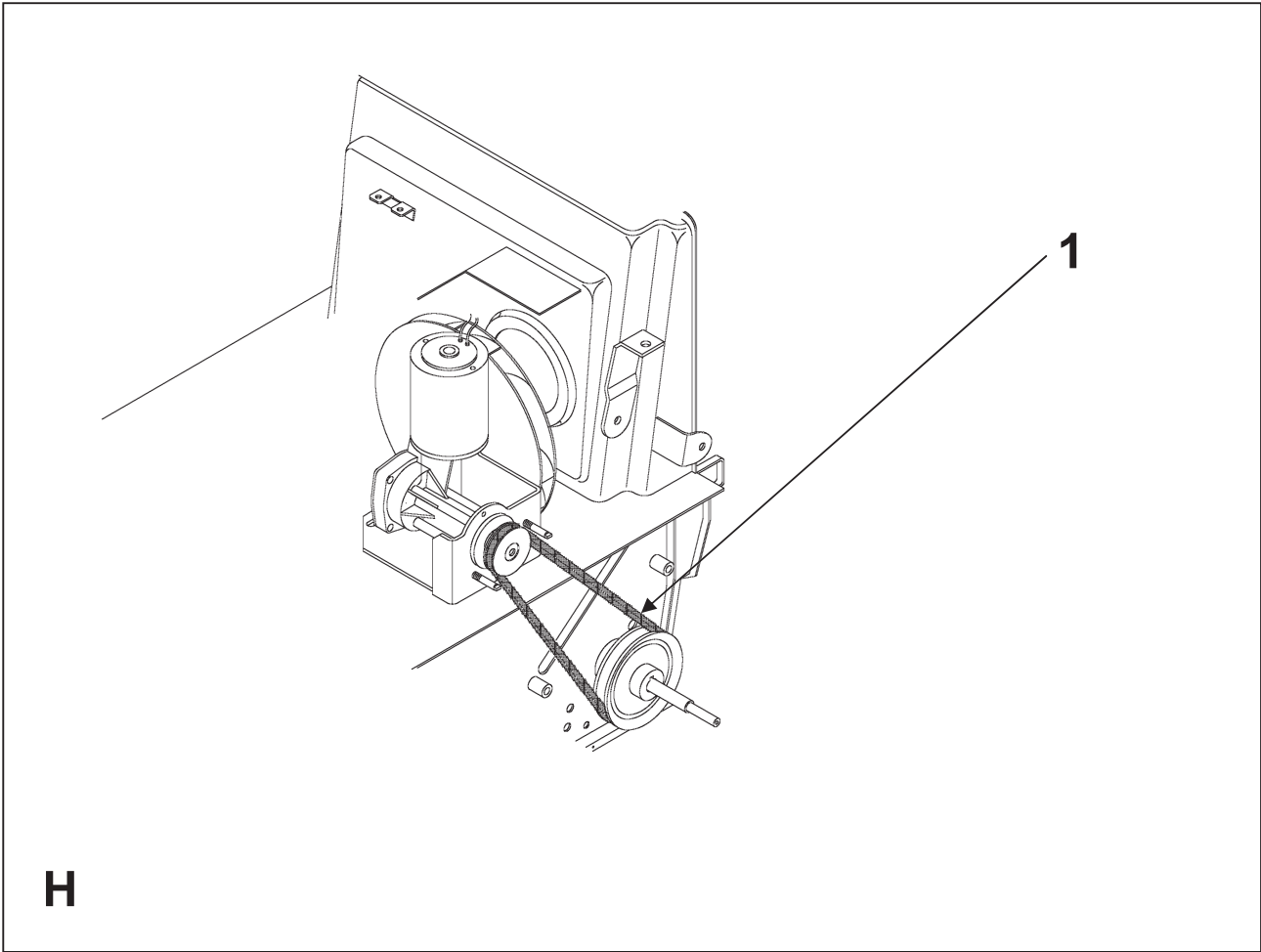
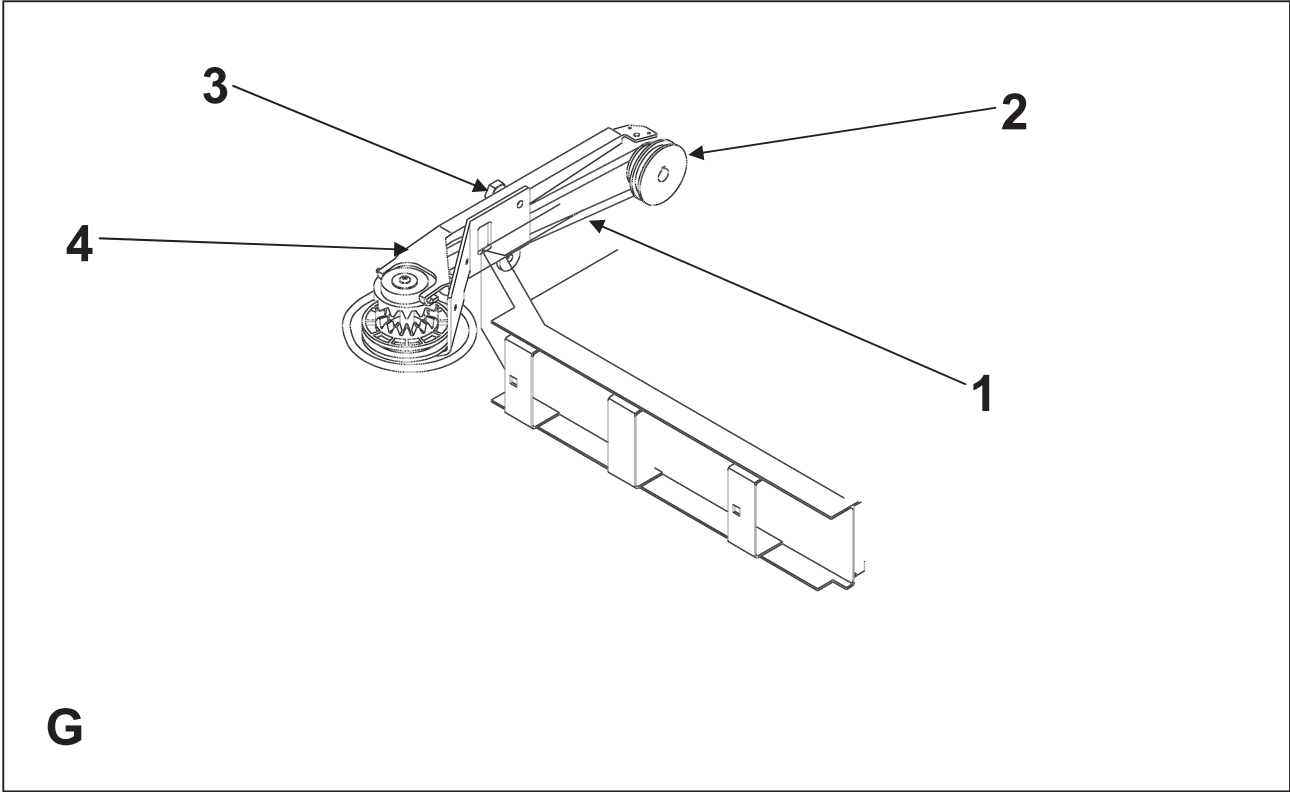

1

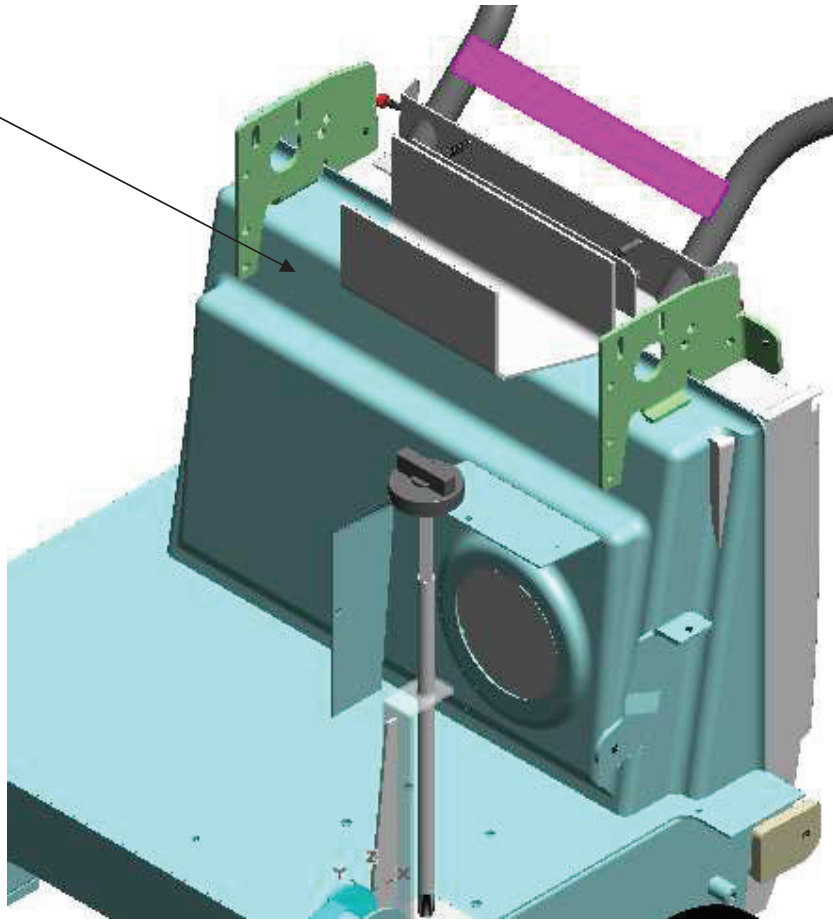

I