



IPC Eagle

Wet/Dry Vacuums

Polyethylene, Polypropylene, & Steel

Operations and Parts Manual



Models:

315P

415P

429P

430P

415S

415ST

415PLT

429ST

IMPORTANT SAFETY INSTRUCTIONS

When using an electrical appliance, basic precaution must always be followed, including the following:

READ ALL INSTRUCTIONS BEFORE USING THIS MACHINE.

This machine is for commercial use.

WARNING



DANGER: Failure to read and observe all DANGER statements could result in severe bodily injury or death. Read and observe all DANGER statements found in your Owner's Manual and on your machine.



WARNING: Failure to read and observe all WARNING statements could result in injury to you or to other personnel; property damage could occur as well. Read and observe all WARNING statements found in your Owner's Manual and on your machine.



CAUTION: Failure to read and observe all CAUTION statements could result in damage to the machine or to other property. Read and observe all CAUTION statements found in your Owner's Manual and your machine.



DANGER: Failure to read the Owner's Manual prior to operating or attempting any service or maintenance procedure to your machine could result in injury to you or to other personnel; damage to the machine or to other property could result as well. You must have training in the operation of this machine before using it. If you or your operator(s) cannot read English, have this manual explained fully before attempting to operate this machine.



DANGER: Operating a machine that is not completely or fully assembled could result in injury or property damage. Do not operate this machine until it is completely assembled. Inspect the machine carefully before operation. Use only as described in this manual. Use only the manufacturer's recommended attachments.



DANGER: Machines can cause an explosion when operated near flammable materials and vapors. Do not use this machine with or near fuels, grain dust, solvents, thinners, or other flammable materials.



DANGER: Do not pick up flammable fluids, dust or vapors.



DANGER: Do not vacuum anything that is burning or smoking, such as cigarettes, matches, or hot ashes.



DANGER: This machine is not suitable for picking up health endangering dust.



DANGER: Using a machine with a damaged power cord could result in an electrocution. Do not use the machine if the power cord is damaged. Do not use the electrical cord to move the machine. Keep cord away from heated surfaces. Do not unplug by pulling on the cord; grasp the plug, not the cord. Turn off all controls before unplugging. Do not close a door on cord or pull around sharp edges or corners.



DANGER: Electrocution could occur if maintenance and repairs are performed on a unit that is not properly disconnected from the power source. Disconnect the power supply before attempting any maintenance or service.



Warning: Operating a machine without observing all labels, decals, etc., could result in injury or damage. Read all machine labels before attempting to operate the machine. Make sure all of the labels are attached or fastened to the machine. Get replacement labels and decals from the manufacturer's distributor.



Warning: Electrical components can "short-out" if exposed to water or moisture. Keep the electrical components of the machine dry. Always store the machine in a dry area.



Warning: Use of this machine to move other objects or to climb on could result in injury to the operator or damage to the machine. Do not use this machine as a step or furniture. Do not allow to be used as a toy. Close attention is necessary when used by or near children.



Warning: Moving parts of this machine can cause injury and/or damage. Keep hands, feet, loose clothing, hair, fingers, and all parts of the body away from openings and moving parts.



Warning: Electrocutation could occur if you handle the plug or appliance with wet hands. Do not handle plug or appliance with wet hands.



Warning: Do not use without dust bag and or filters in place.



Warning: Rotating fan blades inside the cover. Before opening cover, switch off machine. Wait until the fan/brush stops completely or dust and debris may be ejected.



Warning: If the machine is not working properly, has been dropped, damaged, left outdoors, or dropped into water, return it to an Authorized service center.



Warning: Damage could occur to machine if openings are blocked. Do not put any object into openings. Do not use any opening blocked: keep free of dust, lint, hair, and anything that may reduce air flow.



Warning: Injury could occur to the operator or the machine if used without the dust bag and/or filters in place. Do not use the machine without the dust bag and/or filters in place.



Warning: Injury to the operator and/or damage to the machine could occur when cleaning on stairs, unless caution is used. Use extreme caution when cleaning on stairs.



Warning: To reduce the risk of electrical shock, always use a 3-wire electrical system connected to the electrical ground. Whenever possible connect the machine to an outlet protected by a ground fault interrupter (GFCI). See "Grounding Instructions."

SAVE THESE INSTRUCTIONS

120 Volt Machine Instructions For Connection To The Power Supply And The Electrical Ground

This machine must be connected to the electrical ground to protect the operator from electrical shock. The machine has an approved power cord with three conductors and a plug with three terminals. Connect the plug to a receptacle that has three holes and is connected to the electrical ground. The green (or green and yellow) conductor in the cord is the ground wire. Never connect this wire to any terminal other than the ground terminal.

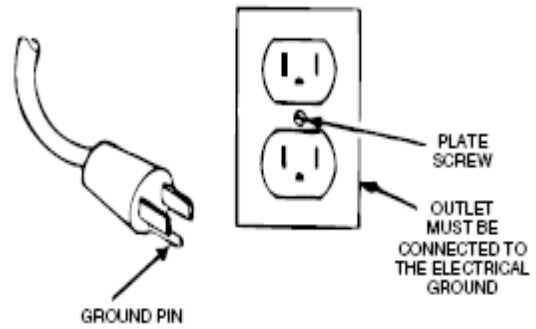

This machine uses a 120 volt AC 60 cycle electrical circuit. Make sure you have the correct frequency and voltage before connecting the power cord to an outlet. The machine has a plug as shown in Figure 1. If a receptacle connected to the electrical ground as shown in Figure 1 is not available, have one installed by an electrical contractor. **Do not use an adapter.**

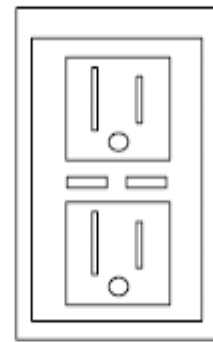

GFCI Outlet



Warning: To reduce the risk of electrical shock, protect the machine from rain. Keep the machine in a dry area.



Warning: To reduce the risk of electrical shock, always use a 3-wire electrical system connected to the electrical ground. Whenever possible connect the machine to an outlet protected by a ground fault interrupter (GFCI).



Warning: Do not cut, remove or break the ground pin. If the outlet does not fit the plug, consult your electrical contractor.



Warning: Have worn, cut or damaged cords and plugs replaced by an authorized service person.



Warning: If it becomes necessary to use an extension cord to reach an electrical outlet, you must use one that is at least one size larger in wire size. Such as a power cord that is marked 12/3 would need to use an extension cord that is marked 10/3. Do not use an extension cord that is undersized.

IMPORTANT INSTRUCTIONS

- Before use, the equipment must be correctly assembled with all of its components
- Check that the electrical outlet is correct for use with the plug on the machine
- Before connecting, check that the specified motor voltage corresponds to the main voltage available
- Never use the equipment near flammable, explosive or toxic substances: sparks from the motor could cause dangerous reactions.
- Always unplug the machine from the electrical outlet when leaving machine unattended or before attempting any repair.
- Service and repair should be done by qualified personnel only. Use only original manufacturer's replacement parts.

Operation

This machine is a commercial vacuum designed for wet or dry pick up. And must be stored in a dry location.

- Machines with dual or triple vac motors can be run together or independently as the job requires.
- Dry soil can be vacuumed directly into the tank or into a disposable paper bag fitted onto the vacuum inlet.
- For wet pick-up, remove polyester filter. The machine is equipped with a shut-off float. As the tank is filled to capacity, a float rises and seals the vac intake, causing a loss of vacuum. Switch off the vacuum when this happens and bring the machine to a drain.
- To empty the machine, either use the drain hose mounted on the back of the tank, or remove the motor head assembly and tilt the tank backwards on tipping models, or lift and dump out the contents of smaller units.
- With both wet and dry applications be sure to frequently clean the filter. This is especially true when the vacuum is being used with strippers and floor finish.

After Use

1. Store the cord on the hook.
2. Store the appliance indoors, away from sources of heat.
3. This appliance is provided with an automatically reset thermal limiter to avoid damage to motor. If thermal limiter operates do one or more of the following:
 - Change the bag
 - Clean or replace the cartridge filter
 - Check hose and tank inlet for any obstructions
 - Wait a few minutes for the thermal limiter to re-close the circuit

Periodic Maintenance

(Every six to twelve months)

1. Check filter for wear, replace dirt saturated filters that do not respond to normal cleaning.
2. Inspect gasket seals and replace those which have begun to leak.
3. Examine carbon motor brushes and commutator.

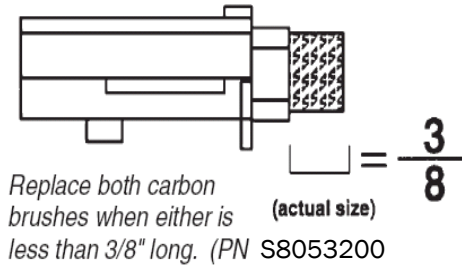

Servicing The Filter

The filter is accessed by lifting the head assembly off the tank.

The Polyester filter assembly is easily removed by simply lifting the filter basket out of the tank.

The cartridge filters they are removed very easily. First remove the filter retainer by turning the black knob 90 degrees counter-clockwise. The cartridge filter will then slide off of the support assembly.

Note:

- Be sure to frequently clean the filters.
- Allow filters to thoroughly air dry after washing them before returning them to the machine.
- Worn filters can affect vacuum performance. Replace the filters when they become worn out and normal cleaning will not restore vacuum performance.

Servicing The Vac Motor

Motor Replacement

1. Disconnect power cord from power source.
2. To access the vac motor, remove the screws that attach the main cover to the head assembly and set the cover to one side.
3. Disconnect the motor's 2 red lead wires from the main wiring bridge.
4. Disconnect green/yellow wire by removing the screw from the motor core.
5. Remove the four motor mounting screws.
6. Remove motor plate and set aside.
7. Take out the motor and remove the upper and lower gaskets.
8. Inspect gaskets. If they show signs of wear replace the.
9. Install gaskets onto new motor ensuring that they are properly seated.
10. Install the new motor. Make sure foam mufflers are positioned properly.
11. Attach motor plate to motor.
12. Connect green/yellow wire to motor core.
13. Connect motor's 2 red lead wires to main wiring bridge.
14. Re-assemble vac cover.
15. Test for proper operation.

Servicing The Vac Motor

Carbon Brush Replacement

(Replacement Carbon Brushes: Part# S8053200)

1. Disconnect power cord from power source.
2. To access the vac motor, remove the screws that attach the main cover to the head assembly and set the cover to one side.
3. Remove the screws that attach the inner cover to the head assembly and set aside.
4. Remove the carbon brush assembly by removing the 2 screws that attach it to the vac motor. See Figure 1
5. Slide off the carbon brush connector from the motor terminal. See Figure 2
6. Inspect armature commuator. If it is extremely pitted, grooved or not concentric then the motor will need to be replaced or sent to a qualified service center.
7. Reverse steps 6 through 4 to install new carbon brush and housing.
8. Repeat steps 4 through 7 for the other carbon brush.
9. Reverse steps 3 and 2 for re-assembly.
10. Test for proper operation.

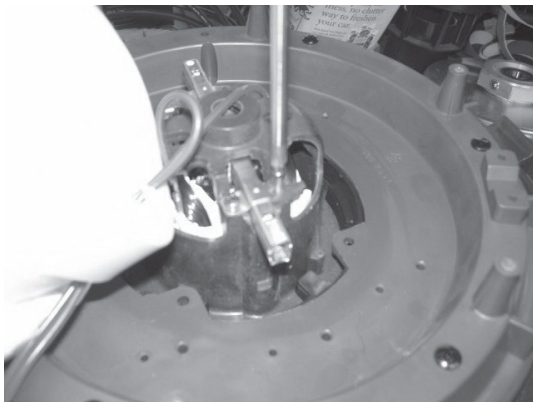

Figure 1

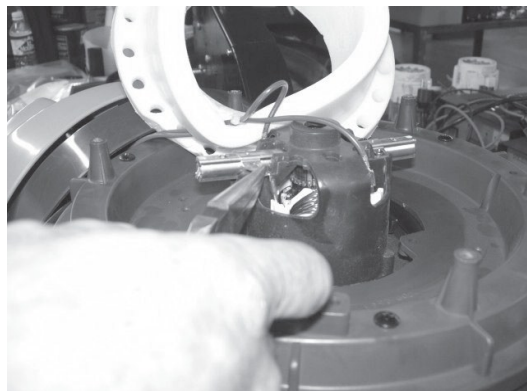
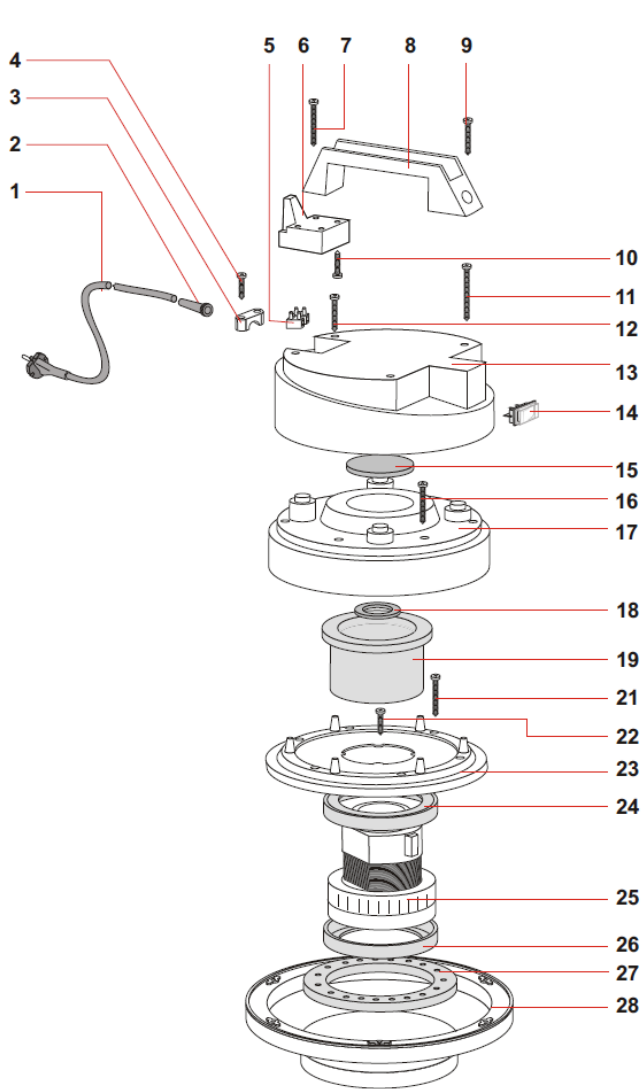
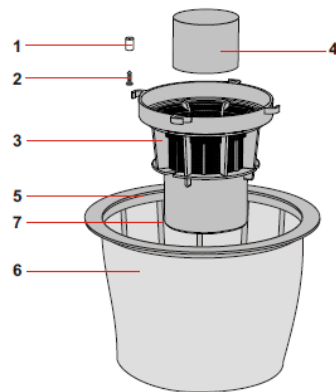

Figure 2

315 Vacuum Motor Assembly



No.	Part #	Description	Qty.
1	S81122	Power Cord	1
2	S80138	Strain Relief	1
3	S80139	Clamp, Cord	1
4	S81006	Screw 5x20	2
5	S83444	Terminal Block	1
6	S82928AUG6	Cord Hook	1
7	S82627	Screw 5x40	1
8	S82927G6	Handle	1
9	S81026	Screw 5x30	1
10	S81006	Screw 5x20	2
11	S81054	Screw 5x50	2
12	S81026	Screw 5x30	2
13	S82929AUG6	Cover, Single Motor 315	1
14	S80326	Switch	1
15	S83937	Filter	1
16	S81050	Screw 5x35	6
17	S82738-1AUVE1	Cover, Motor	1
18	S83969	Gasket	1
19	S83900	Filter	1
21	S82627	Screw 5x40	6
22	S81006	Screw 5x20	4
23	S82591-1AUG6	Motor Retainer	1
24	S83901	Gasket	1
25	S81120S	Motor 1000watt 120V	1
26	S83901	Gasket	1
27	S83866	Disk, Noise Reduction	1
28	S81189GG6	Base, with Gasket	1



Filter Assembly 315

No.	Part#	Description	Qty.
1	S83706	Bushing	4
2	S83724	Screw 5x25	4
3	S82143NE	Body, Float	1
4	S82676	Float	1
5	S80507	Ring, Filter	1
6	S82860	Filter Bag	1
7	S82859	Support, Filter Bag	1

415 Vacuum Motor Assembly

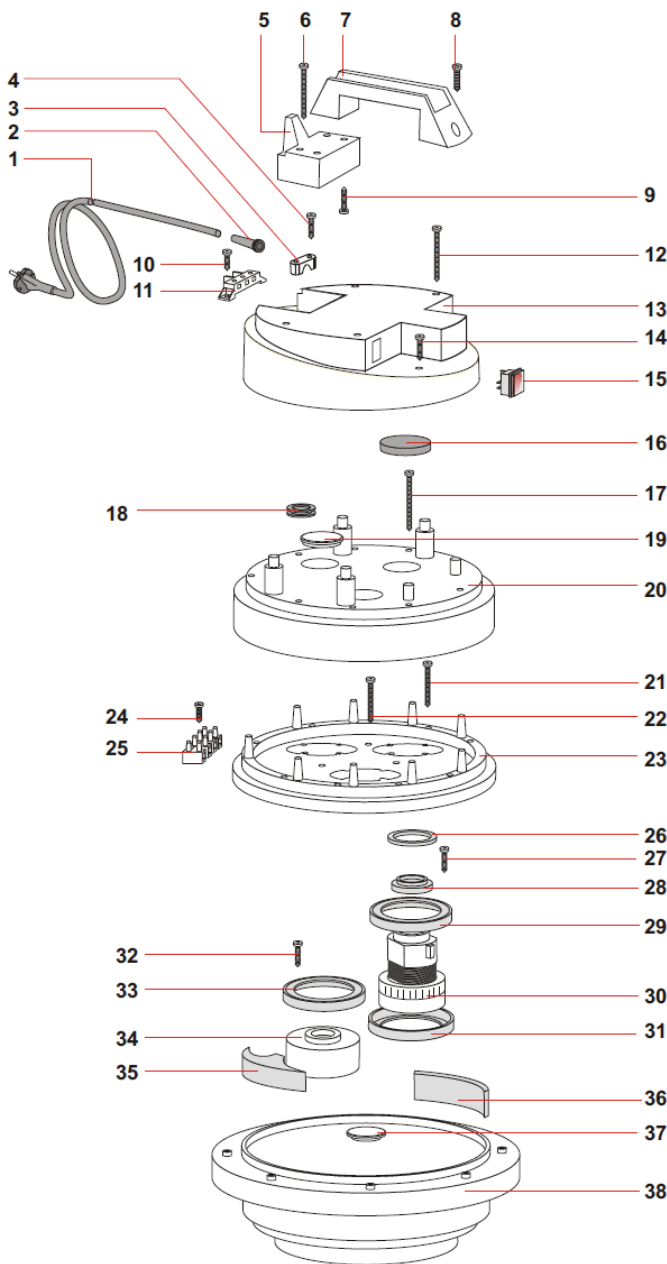

No.	Part #	Description	Qty.
1	S81122	Power Cord 16x3	1
2	S80138	Strain Relief	1
3	S80139	Clamp, Cord	1
4	S81006	Screw, 5x20	2
5	S82931AUG6	Cord Hook	1
6	S81054	Screw 5x30	4
7	S82930G6	Handle	1
8	S81026	Screw 5x25	1
9	S81006	Screw 5x20	2
10	S81005	Screw 5x14	2
11	S83436	Terminal Block	1
12	S81054	Screw 5x30	4
13	S82932AUSK	Cover, Single Motor	1
14	S81006	Screw 5x20	2
15	S80326	Switch	1
16	S83937	Filter	1
17	S83273	Screw 5x35	9
18	S81502	Grommet	1
19	S83383AU	Cap	2
20	S82957AUVEI	Cover, Motor	1
21	S82627	Screw 5x25	9
22	S82627	Screw 5x25	3
23	S82937AUG6	Motor Retainer	1
24	S81004	Screw 4.5x20	1
25	S83433	Terminal Board	1
26	S83969	Gasket	1
27	S81006	Screw 5x20	4
29	S83901	Gasket	1
30	S81120S	Motor 1000watt 120V	1
31	S83901	Gasket	1
32	S81006	Screw 5x20	8
33	S83901	Gasket	2
34	S83451AU	Plug	2
35	S83454	Filter	3
36	S83456	Filter	3
37	S83519	Cap	2
38	S83108G6	Base with Gasket	1

Filter Assembly 415

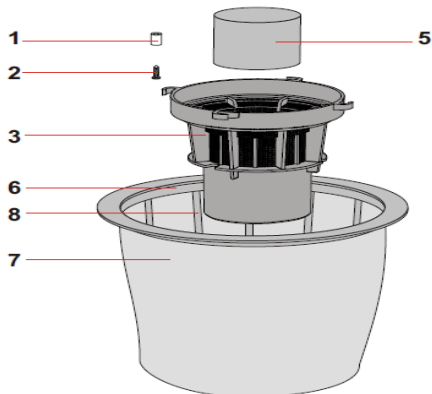

No.	Part #	Description	Qty.
1	S83706	Bushing	4
2	S83724	Screw 5x25	4
3	S821243NE	Body Filter Assembly	1
5	S82676-1G	Float w/Gasket	1
6	S80473	Filter Ring	1
7	S82845	Filter Bag	1
8	S82833-1	Filter Support	1

429 Vacuum Motor Assembly

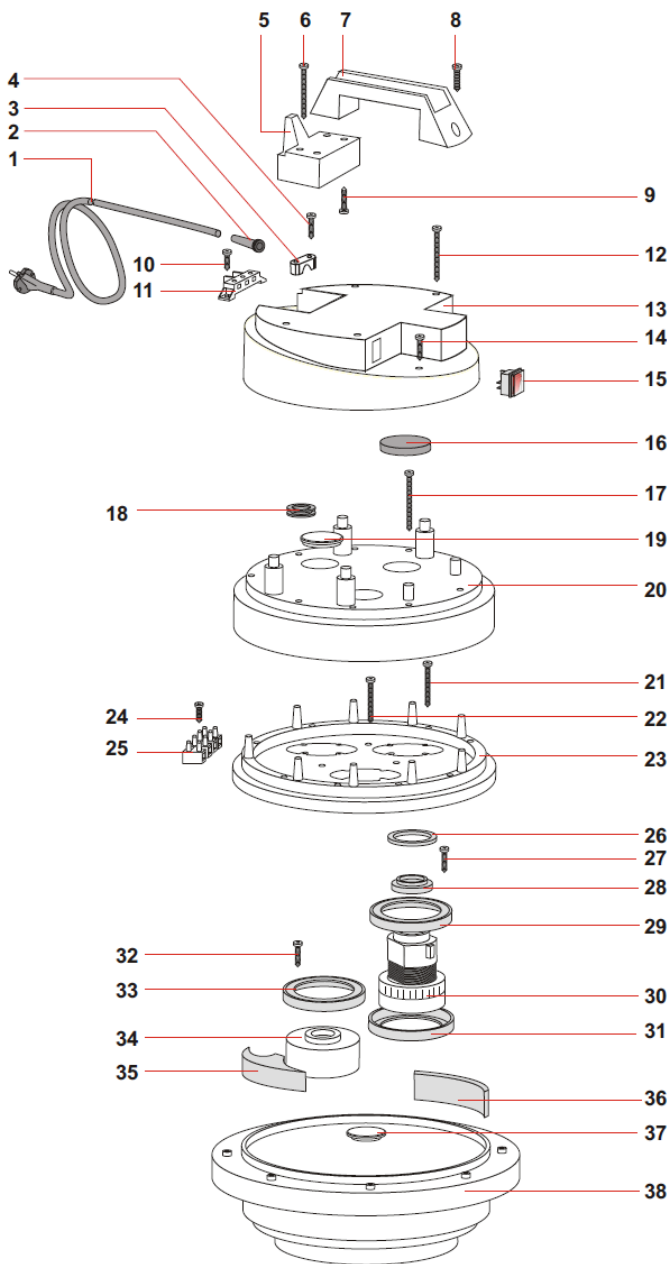

No.	Part #	Description	Qty.
1	T82102005	Power Cord 14x3	1
2	S80138	Strain Relief	1
3	S80139	Clamp, Cord	1
4	S81006	Screw, 5x20	2
5	S82931AUG6	Cord Hook	1
6	S81054	Screw 5x30	4
7	S82930G6	Handle	1
8	S81026	Screw 5x25	1
9	S81006	Screw 5x20	2
10	S81005	Screw 5x14	2
11	S83436	Terminal Block	1
12	S81054	Screw 5x30	4
13	S82963AUG6	Cover, Dual Motor	1
14	S81006	Screw 5x20	2
15	S80326	Switch	2
16	S83937	Filter	2
17	S83273	Screw 5x35	9
18	S81502	Grommet	1
19	S83383AU	Cap	2
20	S82957AUVEI	Cover, Motor	1
21	S82627	Screw 5x25	9
22	S82627	Screw 5x25	3
23	S82937AUG6	Motor Retainer	1
24	S81004	Screw 4.5x20	1
25	S83433	Terminal Board	1
26	S83969	Gasket	2
27	S81006	Screw 5x20	8
29	S83901	Gasket	2
30	S81120S	Motor 1000watt 120V	2
31	S83901	Gasket	2
32	S81006	Screw 5x20	4
33	S83901	Gasket	1
34	S83451AU	Plug	1
35	S83454	Filter	3
36	S83456	Filter	3
37	S83519	Cap	2
38	S83108G6	Base with Gasket	1

Filter Assembly 429

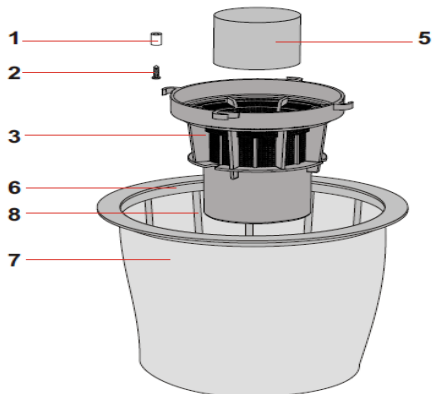

No.	Part #	Description	Qty.
1	S83706	Bushing	4
2	S83724	Screw 5x25	4
3	S821243NE	Body Filter Assembly	1
5	S82676-1G	Float w/Gasket	1
6	S80473	Filter Ring	1
7	S82845	Filter Bag	1
8	S82833-1	Filter Support	1

430 Vacuum Motor Assembly

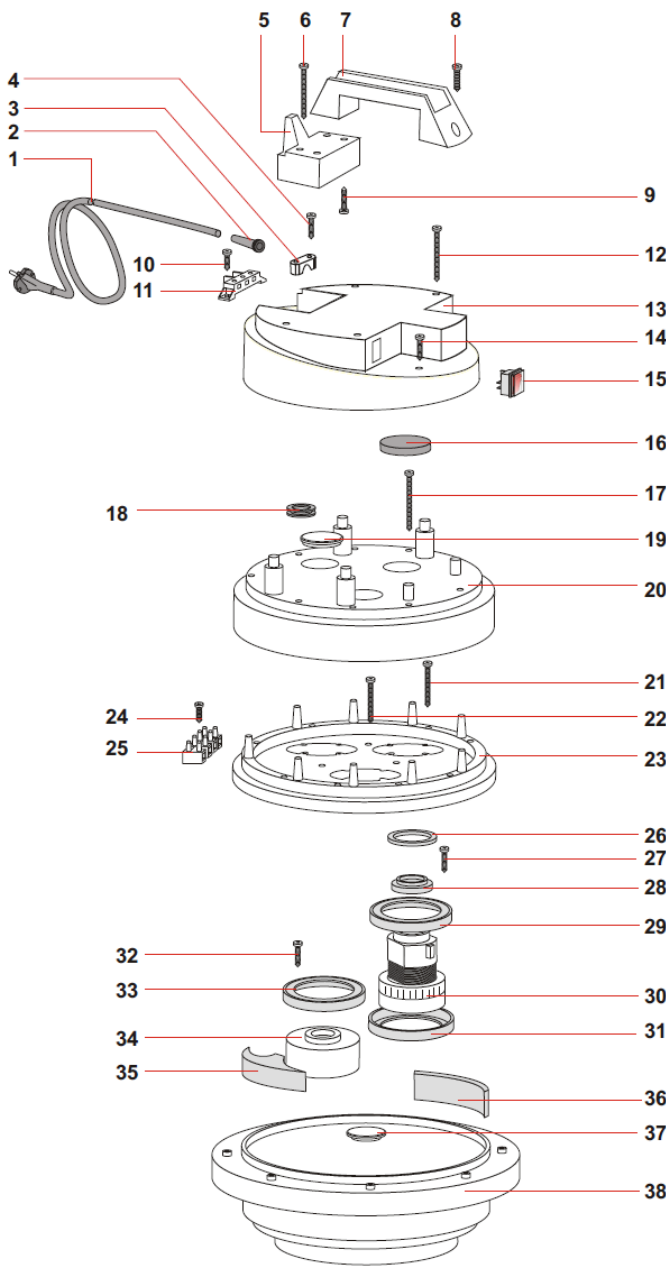

No.	Part #	Description	Qty.
1	T80070	Power Cord 12x3	1
2	S820881	Strain Relief	1
3	S80139	Clamp, Cord	1
4	S81006	Screw, 5x20	2
5	S82931AUG6	Cord Hook	1
6	S81054	Screw 5x30	4
7	S82930G6	Handle	1
8	S81026	Screw 5x25	1
9	S81006	Screw 5x20	2
10	S81005	Screw 5x14	2
11	S83436	Terminal Block	1
12	S81054	Screw 5x30	4
13	S82964AU	Cover, Three Motor	1
14	S81006	Screw 5x20	2
15	S80326	Switch	3
16	S83937	Filter	3
17	S83273	Screw 5x35	9
18	S81502	Grommet	1
19	N/A	N/A	
20	S82957AUVEI	Cover, Motor	1
21	S82627	Screw 5x25	9
22	S82627	Screw 5x25	3
23	S82937AUG6	Motor Retainer	1
24	S81004	Screw 4.5x20	1
25	S83433	Terminal Board	1
26	S83969	Gasket	3
27	S81006	Screw 5x20	12
29	S83901	Gasket	3
30	S81119S	Motor 800watt 120V	3
	T80175	Motor, 800watt 120V High Speed	3
31	S83901	Gasket	3
32	N/A	N/A	
33	N/A	N/A	
34	N/A	N/A	
35	S83454	Filter	3
36	S83456	Filter	3
37	S80468	Valve	3
38	S83108G6	Base with Gasket	1

Filter Assembly 430

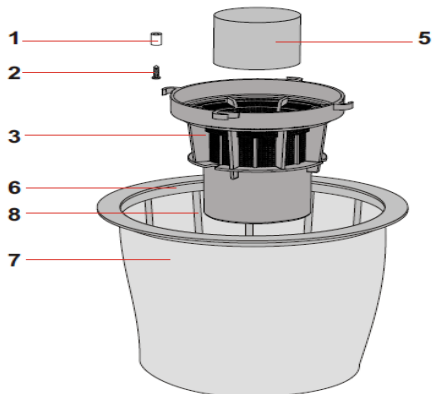

No.	Part #	Description	Qty.
1	S83706	Bushing	4
2	S83724	Screw 5x25	4
3	S821243NE	Body Filter Assembly	1
5	S82676-1G	Float w/Gasket	1
6	S80473	Filter Ring	1
7	S82845	Filter Bag	1
8	S82833-1	Filter Support	1

Tank Assembly 315P

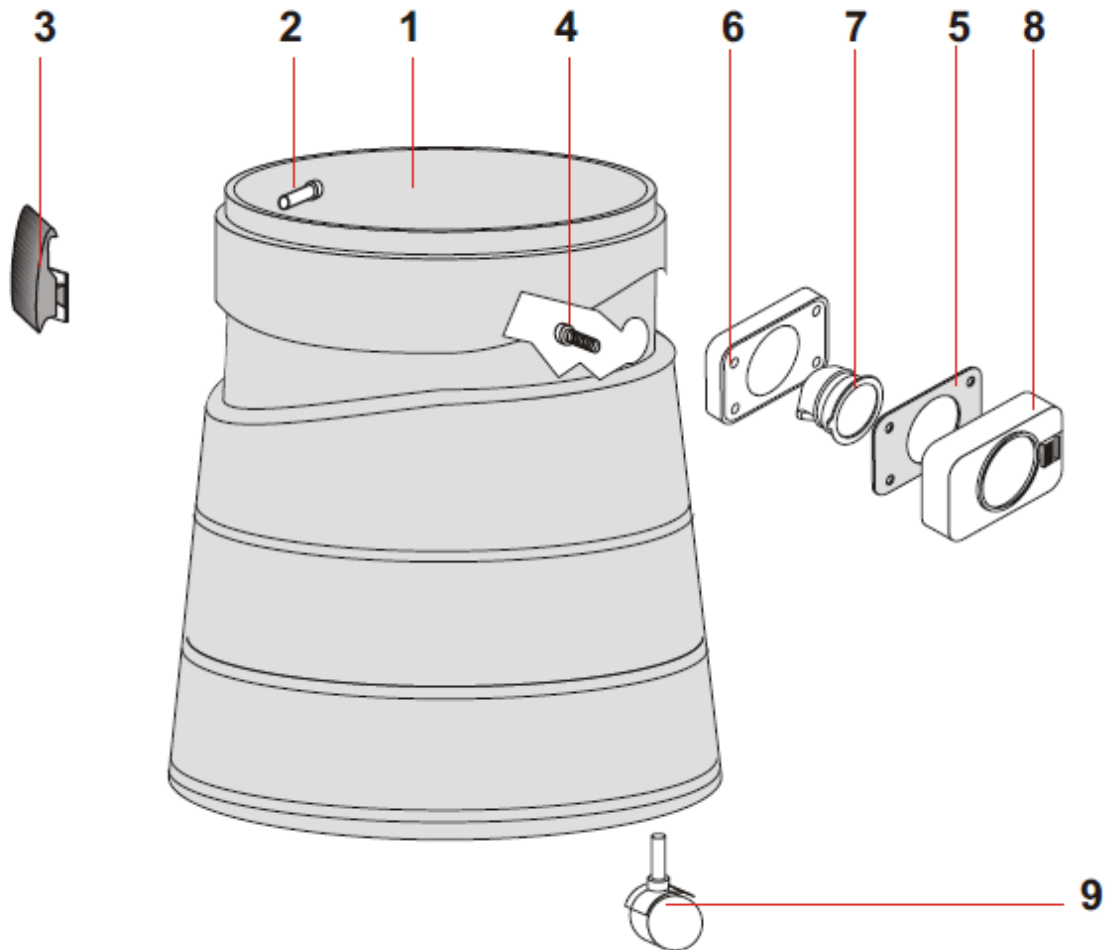

No.	Part#	Description	Qty.
	S82668	Complete Tank Assy.	1
1	S82599	Tank, Black	1
2	S81300	Rivet	4
3	S81847	Clamp	2
4	S81050	Screw 5x35	4
5	S82846	Gasket	1
6	S82586G6	Retainer	1
7	S82593	Deflector	1
8	S82652AG6VE	Inlet Cover	1
9	S80558	Caster	6

Tank and Cart Assembly 415P, 429P, 430P

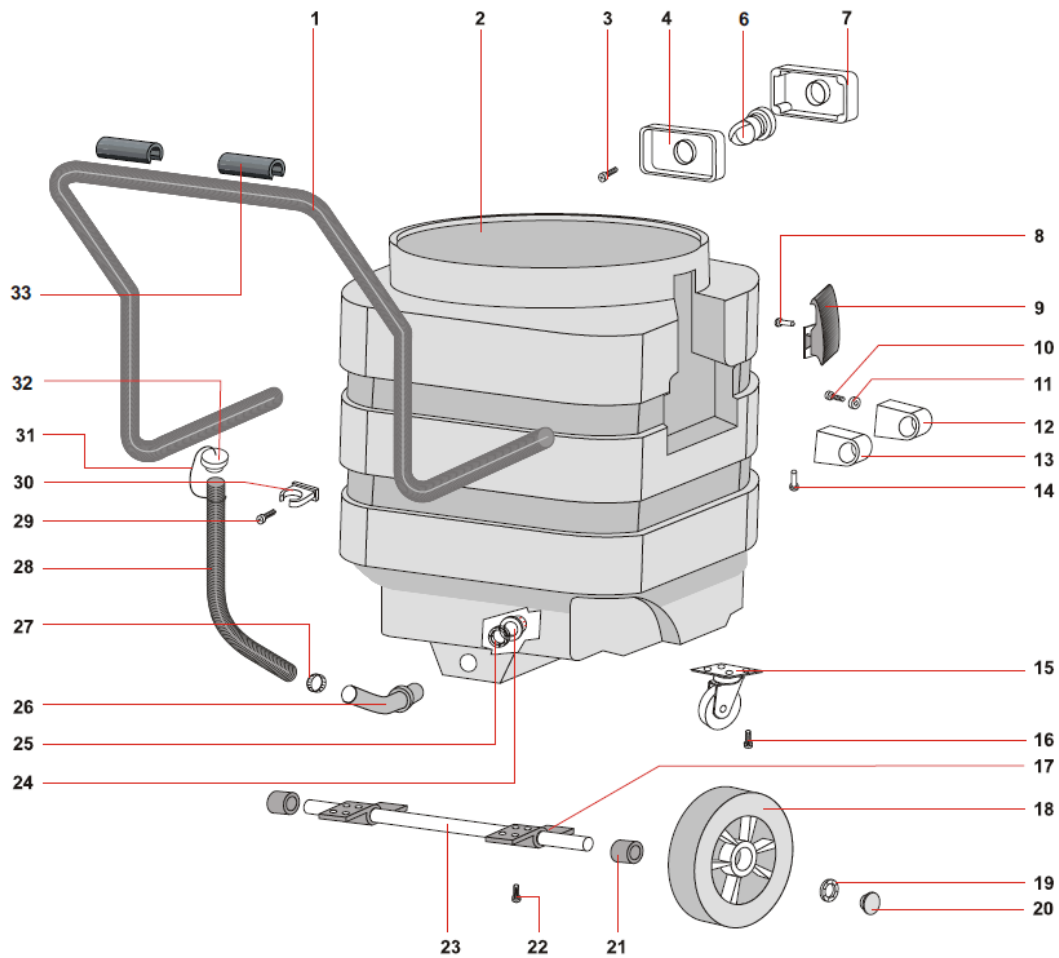

No.	Part#	Description	Qty.	No.	Part#	Description	Qty.
1	S82558	Handle	1	18	S80904	Wheel, Rear	2
2	S82637NE	Tank, Poly 24g Black	1	19	S82557	Retainer, Wheel	2
3	S81026	Screw 5x30	4	20	S83835NE	Cap, Wheel	2
4	S82584G6	Retainer, Tank	1	21	S82607	Spacer, wheel	2
5	S82846	Gasket	1	22	S81006	Screw	8
6	S82593	Deflector	1	23	S82555	Axle	1
6a	S82767	Deflector (430P)	1	24	S80834	Nut, 1.25"	1
7	S82652AG6VE	Inlet Cover w/button	1	25	S80256	Gasket	1
7a	S82762AG6VE	Inlet Cover w/button (430P)	1	26	S82763	Elbow, Drain	1
8	S81300	Rivet	4	27	S83592	Clamp	1
9	S81847	Latch	2	28	S82765	Hose, Drain	1
10	S81050	Screw	8	29	S83156	Screw	1
11	S82974	Washer, Plastic	8	30	S82788	Clamp	1
12	S81072-1NE	Support, Handle Front	2	31	S82812	Retainer, Drain Plug	1
13	S81860-1NE	Support, Handle Rear	2	32	S82764	Drain Plug	1
14	S81302NE	Rivet 4.8x17	2	33	S86250	Handle Grip	2
15	S82559	Caster, Swivel	2				
16	S82680	Screw	8				
17	S82556	Support, Axle	2				

Tank Assembly 415ST

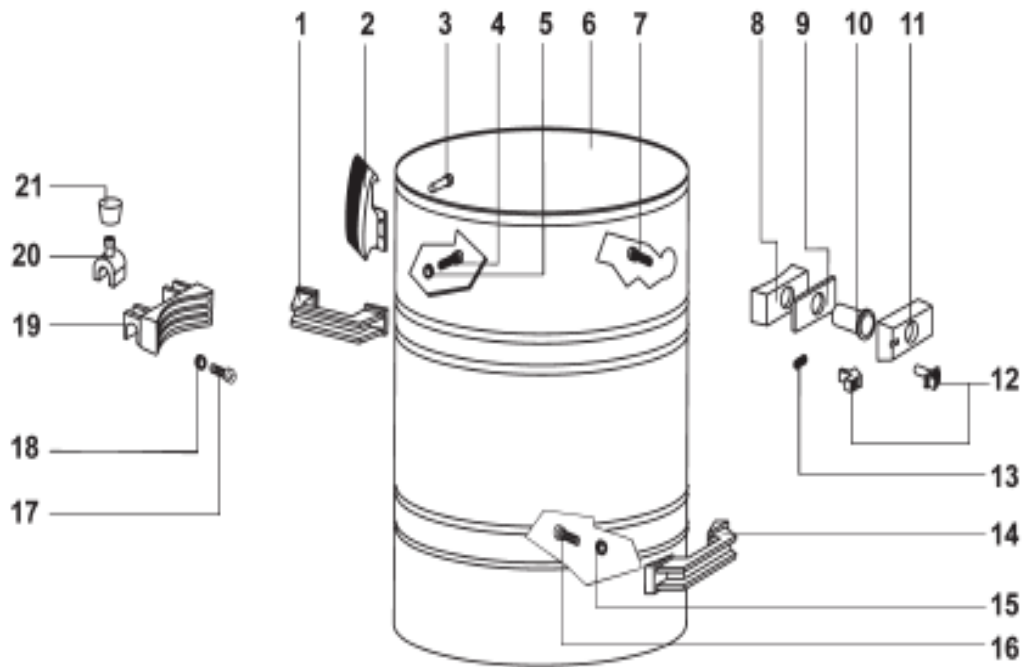

No.	Part#	Description	Qty.
1	S82993	Handle	2
2	S81847	Clamp, Tank	2
3	S81302	Rivet 5x19	4
4	S83629	Screw 5x25	4
5	S83883	Washer	4
6	S83253	Tank-Steel	1
7	S81026	Screw 5x30	4
8	S82586	Adapter, Tank	1
9	S82846	Gasket	1
10	S82593	Deflector	1
11	S82583	Adapter, Hose	1
12	S82594	Button	1
13	S82608	Spring	1
14	S82993	Handle	1
15	S82974	Washer	2
16	S83629	Screw 5x25	2
17	S83156	Screw 5x25	4
18	S83883	Washer	4
19	S82968	Hook, Tank	1
20	S82970	Swivel	2
21	S82969	Knob, Release	2

Cart Assembly 415ST

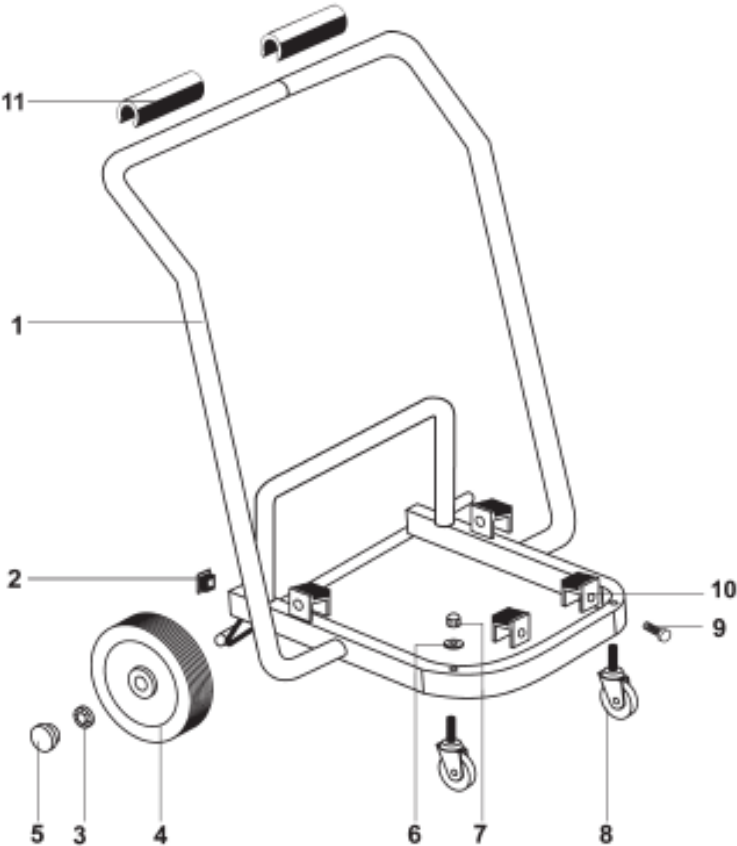

No.	Part#	Description	Qty.
1	S83250	Cart	1
2	S80976	Plug	2
3	S82557	Cap, End	2
4	S80904	Wheel	2
5	S83835	Cap	2
6	S81012	Washer	2
7	S80478	Nut	2
8	S80479	Caster, Swivel	2
9	S81979	Screw 5x25	4
10	S83450	Clip Pad	4
11	S86250	Hand Grip	2

Tank Assembly 415S

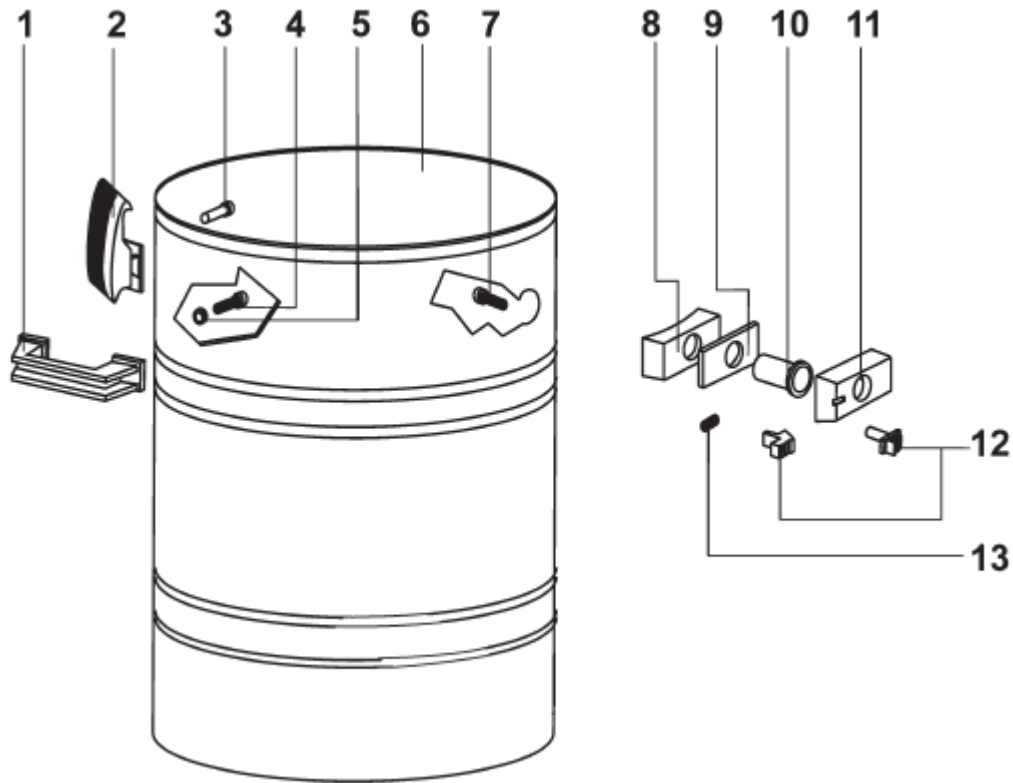

No.	Part#	Description	Qty.
1	S82993	Handle	2
2	S81847	Clamp, Tank	2
3	S81302	Rivet 5x19	4
4	S83629	Screw 5x25	4
5	S83883	Washer	4
6	S80476	Tank	1
7	S81026	Screw 5x30	4
8	S82586	Adapter, Tank	1
9	S82846	Gasket	1
10	S82593	Deflector	1
11	S82583	Inlet Cover	1
12	S82594	Button	1

Cart Assembly 415S

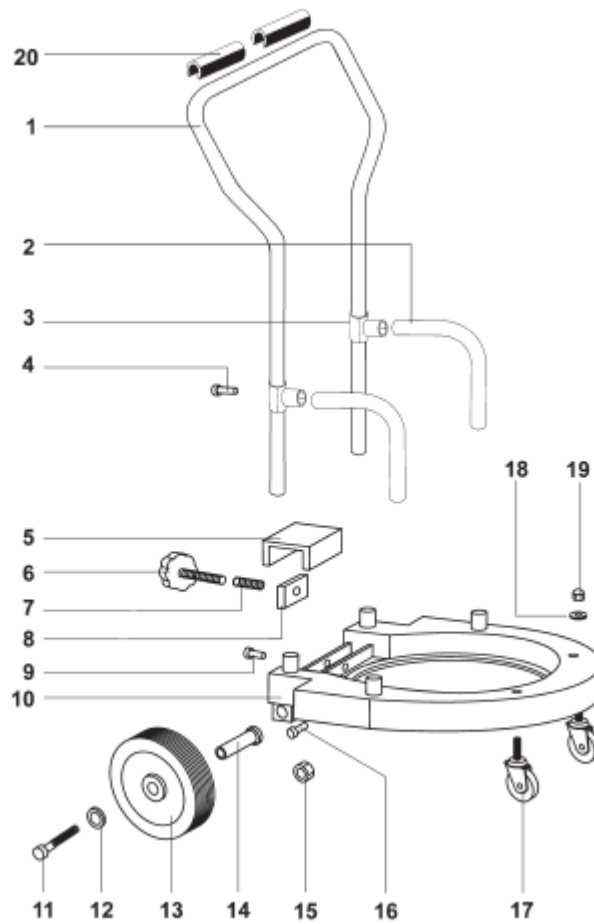

No.	Part#	Description	Qty.
1	S82993	Handle	1
2	S80917	Support, Handle	2
3	S80913	T-Tube	2
4	S81301	Rivet 5x11	2
5	S80902	Block	1
6	S80914	Hand Wheel 8x60	1
7	S81402	Spring	1
8	S81403	Plate, Threaded	1
9	S81301	Rivet 5x11	2
10	S80901	Base, Cart	1
11	S80915	Screw 12x140	2
12	S81028	Masher M12	2
13	S80904	Wheel	2
14	S81401	Bushing	2
15	S82052	Spacer	2
16	S81301	Rivet 5x11	2
17	S80479	Caster	2
18	S81012	Washer	2
19	S80478	Nut M10	2
20	S86250	Hand Grip	2

Tank Assembly 415PLT

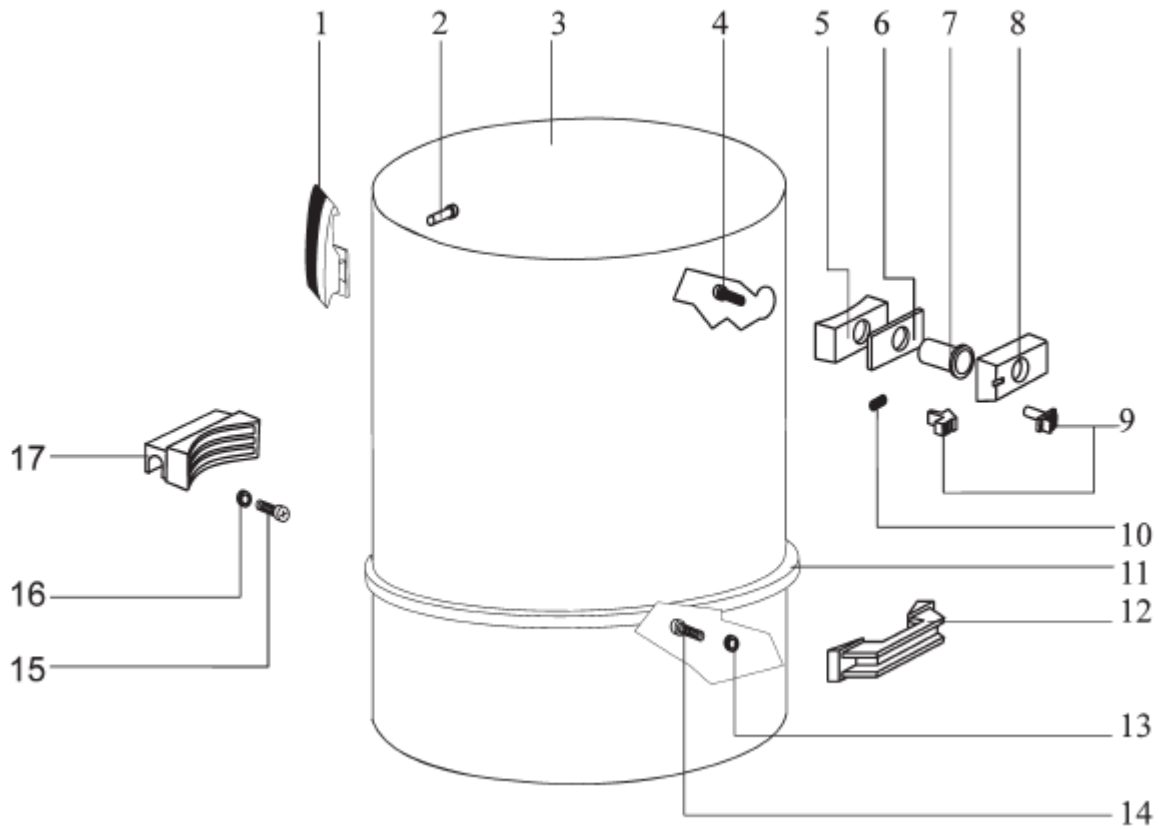

No.	Part#	Description	Qty.
1	S81847	Clamp, Tank	2
2	S81300	Rivet 5x24.5	4
3	S83773	Tank	1
4	S81026	Screw 5x30	4
5	S82586	Adapter, Tank	1
6	S82846	Gasket	1
7	S82593	Deflector	1
8	S82583	Inlet Cover	1
9	S82594	Button	1
10	S82608	Spring	1
11	S83771	Bumper	1
12	S82993	Handle	1
13	S83883	Washer, Plastic	2
14	S81026	Screw 5x30	2
15	S81026	Screw 5x30	4
16	S83883	Washer, Plastic	4
17	S82172	Hook, Tank	1

Cart Assembly 415PLT

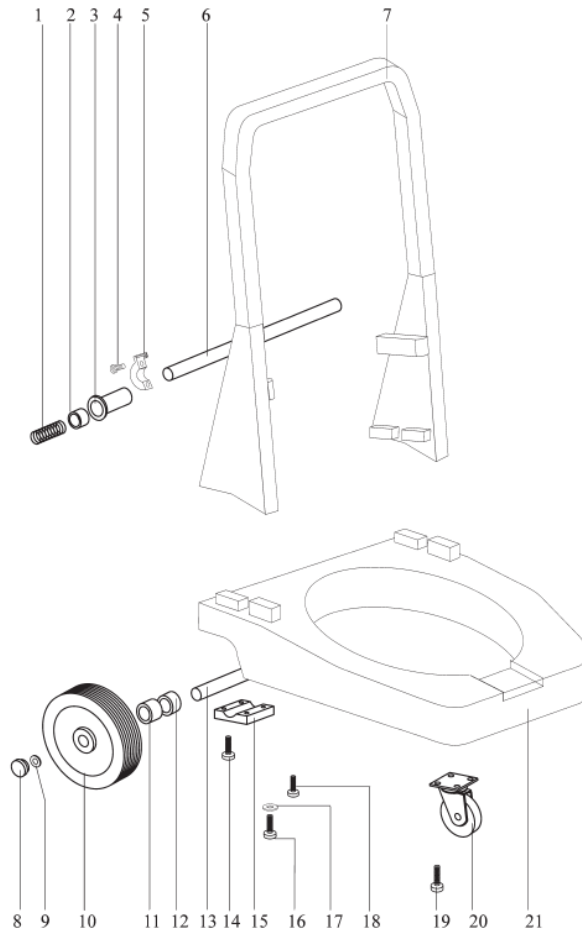

No.	Part#	Description	Qty.
1	S82053	Spring	2
2	S82607	Spacer	2
3	S82173	Lock, Plastic	2
4	S81979	Screw 5x25	4
5	S83725	Clamp	2
6	S83751	Shaft	1
7	S83694	Handle	1
8	S83835	Cap, Axle	2
9	S82557	Cap, End	2
10	S80904	Wheel	2
11	S82607	Spacer	2
12	S82980	Spacer	2
13	S83752	Axle	1
14	S81026	Screw 5x30	8
15	S82967	Support, Axle	2
16	S81050	Screw 5x35	2
17	S82974	Washer	6
18	S82627	Screw 5x40	12
19	S81006	Screw 5x20	8
20	S82559	Caster	2
21	S83797	Base, Cart	1

Tools



Item	Part#	Description	Qty
	S72672	Complete Tool Kit	1
1	S70003	Crevice Tool	1
2	S76295	Round Brush	1
3	S70008	Hose	1
4	S76387	Wand, Straight	2
5	S76389	Wand, Curved	1
6	S76384	16" Floor Brush	1
7	S76385	16" Floor Squeegee	1
7a	S82333	Replacement Squeegee Blades	2
1	S76388	Adapter	1

Not shown: Adaptor 2" Tank inlet to 1.5" raw hose—Used on 3 motor models due to 2" tank inlet

Filters

Part#	Description	Where Used
S82860	Filter Bag, Standard Polyester	315 models
S82845	Filter Bag, Standard Polyester	415/429/430 models
S83742*	Cartridge Filter, Paper	315 models
S73742*	Cartridge Filter, Polyester	315 models
S82881*	Cartridge Filter, HEPA Equivalent	315 models
S82852*	Cartridge Filter, Paper	415/429/430 models
S76061*	Cartridge Filter, Polyester	415/429/430 models
S82995*	Cartridge Filter, HEPA Equivalent	415/429/430 models
S82855	Cartridge Filter Retainer	all models
T80092	Paper Filter Bags 5/pkg.	315 models
T80093	Paper Filter Bags 3/pkg.	415/429/430 models

**also requires S82855 Retainer*

Recommended Spare Parts

S8TOEG845	Motor Carbon Brush
S80326	Main Power Switch
S82860	Polyester Filter, 315
S82845	Polyester Filter, 415/429/430

S70042 22" Front-Mounted Squeegee fits all 415/429/430 models

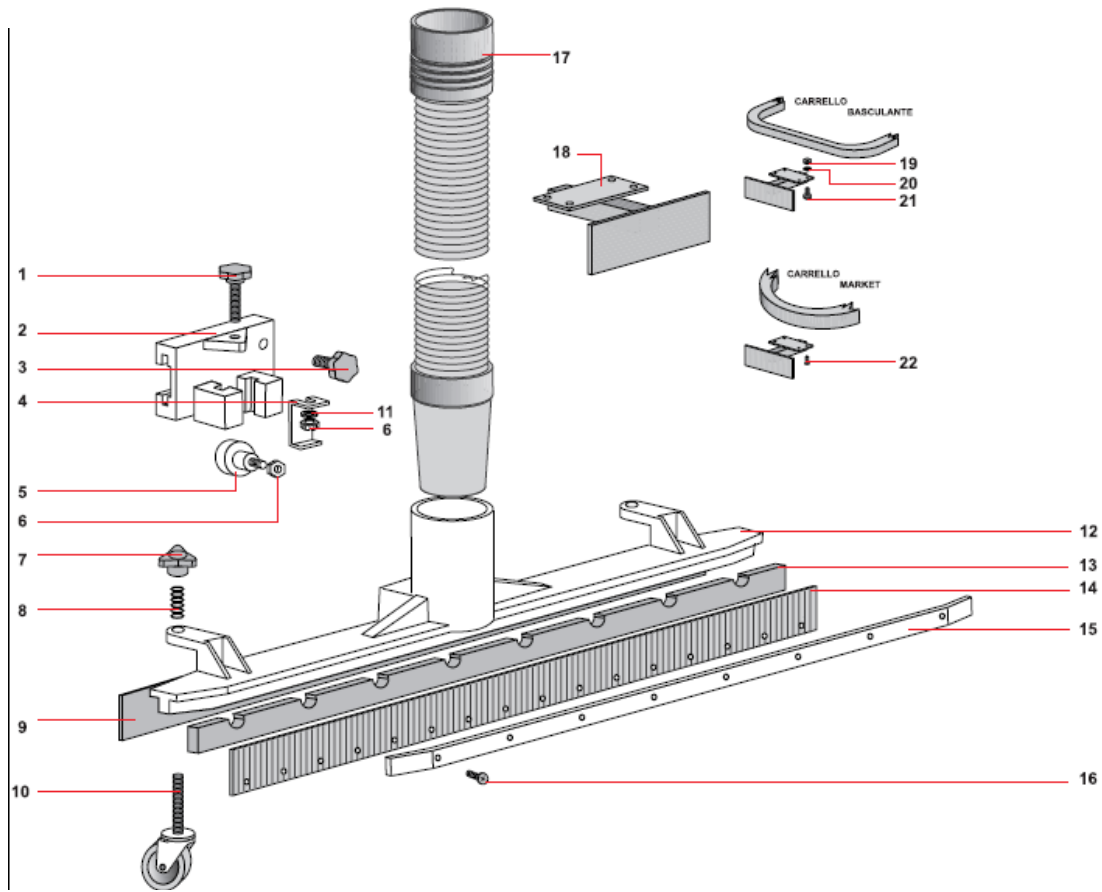

No.	Part#	Description	Qty.
1	S82164	Handwheel 8x45	1
2	S82187	Small Block, Fixed	1
3	S82163	Handwheel 6x25	1
4	S83115	Plate, Adjustment	1
5	S82189	Driver Pivot	1
6	S81033	Nut M8	2
7	S81732	Adjustment Knob	2
8	S86137	Spring	2
9	S82245	Squeegee, Rear	1
10	S86138	Wheel	2
11	S81034	Washer M8	1
12	S82177	Body, Wet Fix Tool	1
13	S82198	Spacer	2
14	S82196	Squeegee, Front	1
15	S82197	Bracket, Squeegee	2
16	S81856	Screw M4x16	16
17	S80010	Hose	1
18	S82297	Mounting Bracket	1
19	S81035	Nut M5	4
20	S81036	Washer M5	4
21	S81755	Screw 5x16	4
22	S81006	Screw 5x20	4

T80184 30" Front-Mounted Squeegee fits 415/429/430 models with Polyethylene Tanks

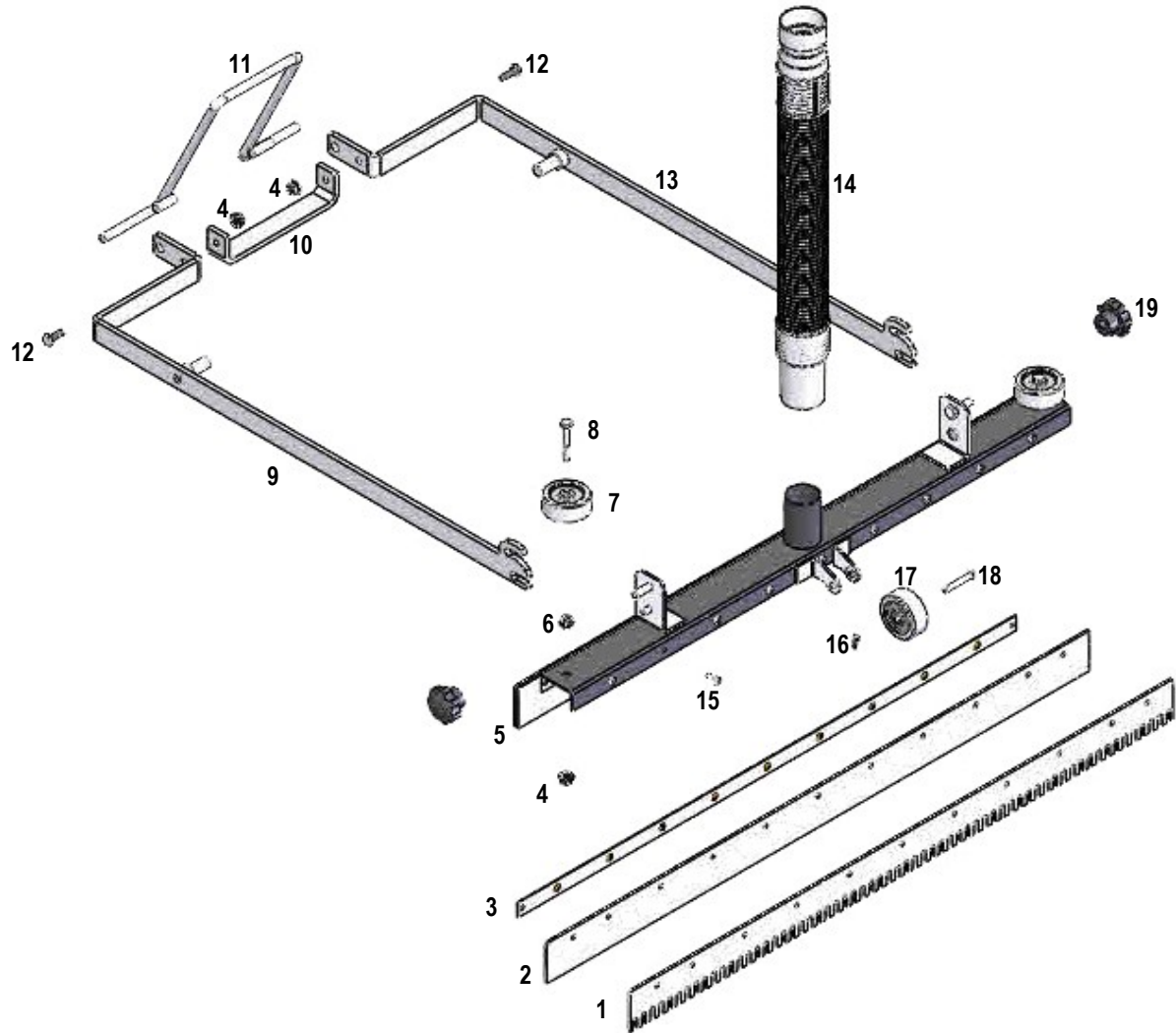

No.	Part#	Description	Qty.
1	BD735602	Blade, Slotted	2
2	BD735601	Blade, Solid	2
3	BD7015509	Support, Blade	2
4	BD41000	Nut, Nylock 1/4-20	4
5	BD715508	Housing Assy.	1
6	BD41000	Nut, Nylock 1/4-20	2
7	BD735607	Wheel, Guide	2
8	BD735608	Bolt, 1/4-20 x 1.75"	2
9	BD725520	Lifting Arm RH	1
10	BD705202	Cross Member	1
11	BD705203	Latch Assy.	1
12	BD40505	Bolt, 1/4-20 x 1"	2
13	BD725521	Lifting Arm, RH	1
14	T80021	Hose Assy.	1
15	BD408000	Screw, 10, 32x625L	18
16	BD735620	Clevis Pin, Front Wheel	1
17	BD735617	Front Guide Wheel, 2" Dia	1
18	BD735619	Hitch Pin, Front Wheel	1
19	BD735618	Hand knob, Front Mount	2

T80054 30" Front-Mounted Squeegee fits 415PLT Plastic Tipping Tank

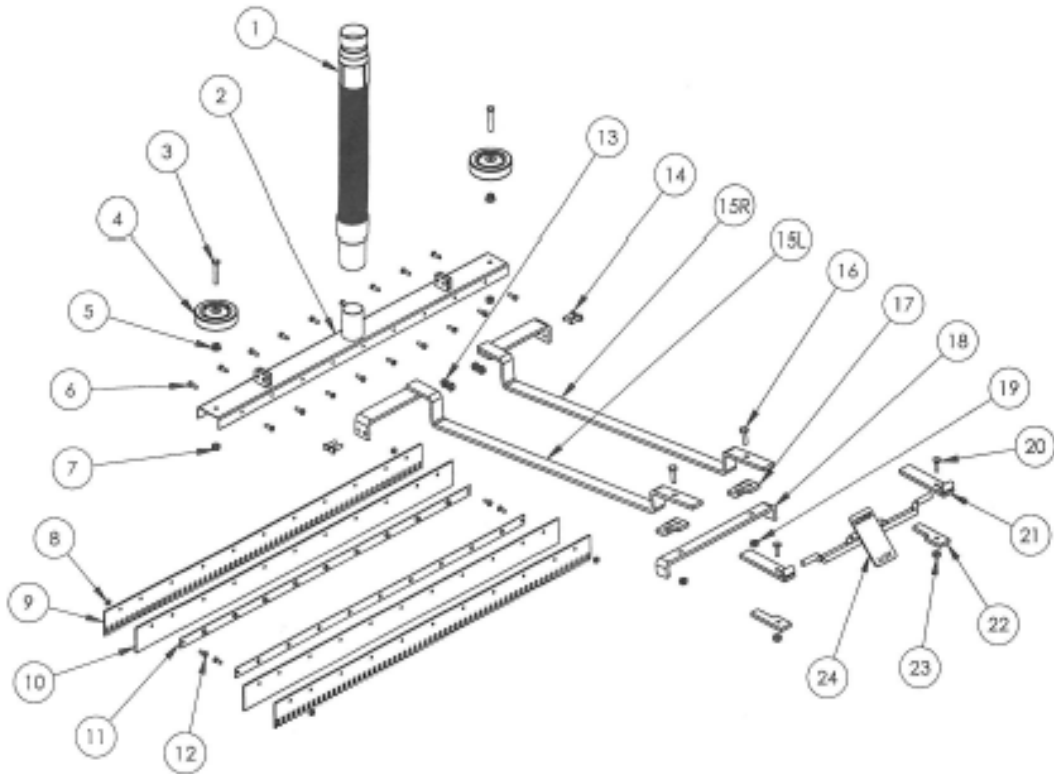

No.	Part#	Description	Qty.
1	T80021	Hose Assy.	1
2	BD715508	Housing	1
3	BD735608	Bolt, Guide Wheel 1/4-20 x 1.75"	2
4	BD735607	Guide Wheel	2
5	BD735611	Jam Nut 1/4-20	2
6	BD735603	Screw 10-32 x 5/8"	18
7	BD735609	Nylock Nut 1/4-20	2
8	BD735605	Nylock Nut 10-32	4
9	BD735602	Blade, Slotted	2
10	BD735601	Blade, Solid	2
11	BD715509	Blade Support	2
12	BD735603	Screw 10-32 x 5/8"	18
13	BD735609	Nylock Nut 1/4-20	4
14	BD735612	Bolt 1/4-20 x 3/4"	4
15	BD705225R	Lifting Arm, Right Side	1
16	BD705225L	Lifting Arm, Left Side	1
17	BD705209	Clamp, Lifting Arm	2
18	BD705210	Cross Member	1
19	BD735614	Nylock Nut 5/16-18	2
20	BD735612	Bolt 1/4-20 x 3/4"	2
21	BD705212	Pedal Mount	2
22	BD705209	Clamp, Pedal Mount	2
23	BD735609	Nylock Nut 1/4-20	2
24	BD705229	Pedal Assy.	1

Warranty Policy

Limited Warranty

IPC Eagle warrants new cleaning equipment against defects in material and workmanship under normal use and service to the original purchaser as detailed below.

3 years

Subject to the conditions stated below, IPC Eagle warrants all Polyethylene Tanks to be free from defects in materials and workmanship for a 3-year period. Parts replaced or repaired are warranted for the remainder of the original warranty period.

1 year

Subject to the conditions stated below, IPC Eagle warrants all other cleaning equipment components to be free from defects in materials and workmanship for a 1-year period. Parts replaced or repaired are warranted for the remainder of the original warranty period.

IPC Eagle will furnish and charge for replacement parts, including transportation, to the original owner through an IPC Eagle authorized service center. If the part is returned within 30 days and is found defective, the owner will be credited for the cost of the replacement part including shipping and handling.

Labor charges are covered for one year from the date of purchase if provided by an authorized IPC Eagle service center.

Wear items exempt from warranty include belts, carbon brushes, power cords, wheels, brushes, pads, handle grips, filters, screens, hoses, and squeegees.

This warranty shall not apply to failures caused by misuse or abuse, improper maintenance as stated in the operation manuals, use of unauthorized repair parts, repairs by other than an IPC Eagle authorized service center, and damage in transit.

IPC Eagle disclaims and denies any liability for any direct, indirect, special incidental or consequential damage which may be suffered as a result of sale, delivery, servicing, use, loss of any product, downtime, labor, freight, or other charges not expressly included herein.



IPC Eagle

3650 Dodd Rd • Eagan, MN 55123
651.686.5399 • Fax 651.686.5695 • 800.486.2775
www.ipceagle.com

IPC Eagle Corporation Sales and Service Provided By: